
**Europäisches Patentamt**  
**European Patent Office**  
**Office européen des brevets**

⑪ Publication number: **0 094 193**  
**B1**

⑫ **EUROPEAN PATENT SPECIFICATION**

- ④⑤ Date of publication of patent specification: **19.08.87**
- ⑤① Int. Cl.<sup>4</sup>: **G 01 N 15/00, C 12 M 1/34, G 01 N 1/28**
- ⑦① Application number: **83302503.4**
- ⑦② Date of filing: **04.05.83**

⑤④ **System and methods for cell selection.**

- ③⑧ Priority: **10.05.82 CH 2897/82**
- ④③ Date of publication of application: **16.11.83 Bulletin 83/46**
- ④⑤ Publication of the grant of the patent: **19.08.87 Bulletin 87/34**
- ⑧④ Designated Contracting States: **AT BE CH DE FR GB IT LI LU NL SE**
- ⑤⑥ References cited:  
**DE-A-2 928 790**  
**GB-A- 770 229**  
**US-A-3 776 699**  
**US-A-3 899 610**  
**US-A-4 066 359**  
**US-A-4 131 800**

- ⑦③ Proprietor: **BAR-ILAN UNIVERSITY**  
**52 100 Ramat Gan (IL)**
- ⑦⑦ Inventor: **Weinreb, Arye**  
**8 Shiler Street**  
**Jerusalem 92 227 (IL)**  
 Inventor: **Deutsch, Mordechai**  
**14 Don Joseph Nassi Street**  
**Peta Tiqva 49 386 (IL)**
- ⑦④ Representative: **Miller, Joseph et al**  
**J. MILLER & CO. Lincoln House 296-302 High**  
**Holborn**  
**London WC1V 7JH (GB)**

**BIOPHYSICAL JOURNAL, vol. 23, no. 1, 1978,**  
**pages 395-405, Biophysical Society; L. CERCEK**  
**et al.: "Fluorescein excitation and emission**  
**polarization spectra in living cells"**  
  
**"Methods of Cell Separation", vol. 1, 1977,**  
**pages 229-249, chapter 6, K. SHORTMAN: "The**  
**separation of Lymphoid cells on the basis of**  
**physical parameters: separation of B- and**  
**T-cell subsets and characterization of B-cell**

- ⑤⑧ References cited:  
**differentiation stages", edited by N.**  
**Catsimpoolas, Plenum Press, New York, US;**  
  
**"Methods of cell separation", vol. 1, 1977, pages**  
**193-223, chapter 5, U.S. RUTISHAUSER et al.:**  
**"Fractionation and manipulation of cells with**  
**chemically modified fibers and surfaces",**  
**edited by N. Catsimpoolas, Plenum Press, New**  
**York, US**

Note: Within nine months from the publication of the mention of the grant of the European patent, any person may give notice to the European Patent Office of opposition to the European patent granted. Notice of opposition shall be filed in a written reasoned statement. It shall not be deemed to have been filed until the opposition fee has been paid. (Art. 99(1) European patent convention).

**EP 0 094 193 B1**

**Description**

The present invention refers to equipment and methods for cell selection and, more particularly, to such equipment and methods for trapping individual cells at known locations thereby for use among other ways in selecting at least one sub-population of cells, using defined parameters common to its members, from a more general cell population.

Equipment and methods for selecting and separating sub-populations of biological cells, e.g. those contained in the blood, are known, as is made clear in the prior art portions of claims 1 and 17 herein, see for instance document DE—A—2928790. Several methods which are considered to be important and indicative of the state of the art are briefly described and commented on below.

Separation based on cell adhesion. This method is not very efficient and is not suited for separation of different cells which have the same membranaric characteristics, e.g. between cells that stick to glass.

Immunofluorescence separation. This method is based on known binding characteristics of subpopulations of cells to certain antigens and/or antibodies. Their binding to the cells in a later stage can be used to identify the cell. However, this method is quite limited because it cannot be used to separate cells based on measurements of their biological activities or response to the bound matter.

Electrophoresis. This method is based on cell-separation according to the cells' electrical charge. Thus, it cannot be used to separate different groups of cells having the same charge, or mass. Radio assay including radio immunoassay, radio incorporation assay, radio enzymological assay. In this method one cannot separate groups of cells from one another, nor distinguish a subgroup within the group based on its activity or inactivity and response.

Morphology. Distinction between cells is based on their physical appearance. This method is quick but the coarsest of all.

Cell separation according to specific density (gradient technique). In this method cells float upon an isotonic solution of known density, osmolarity and viscosity. This configuration is subjected to acceleration forces by centrifugation at a given temperature and acceleration. The cells, having a specific weight greater than that of the solution sink. Those having the specific density of the solution are suspended in it, and those with a specific density less than that of the solution float above it. The main problem with this method is the cells' compartmentization within the density gradient, which is influenced by ambient conditions such as temperature, osmolality, acceleration, e.g. the distance of the interface between the blood and the gradient from spinning axis.

In addition to the above-stated shortcomings of the various prior art methods, a disadvantage

common to all of them is due to the fact that the separated cells nearly always include cells belonging to other than the group or subgroup of interest. Therefore, any diagnosis of the cells, separated by any of these mentioned methods, is necessarily coarse, even if all the procedures have been carried out with the utmost precision.

For example, L. Cereck et al describe a SCM-test (Structuredness of Cytoplasmic Matrix) in Biophys. J., July 1978, Vol. 23, No. 1, p. 395 ff. In said article the authors admit that by the above described gradient method, separated cells contained about 50% of undesired cells, in spite of the great care with which the test was conducted.

Therefore, it is a major object of the invention to provide a method and equipment for selecting a group of cells from other cells and further separate the selected cells from one another. Each of the selected cells, separated from one another, is at a precise known location. All the selected cells are subjectable to common tests, yet the effect on each individual cells is determinable, thereby enabling more accurate diagnosis. The tests and the effects on each cell are performed automatically in order to reduce the testing time, a task performable by relatively unskilled personnel.

The inability to totally separate a particular groups of cells from all other greatly affects the diagnosis accuracy. Furthermore, and most significantly, in the above described methods, cell separation and the following tests conducted thereon are on a macro or batch basis, rather than on a micro basis, i.e. one in which the selected cells are separated from one another and each cell can be separately tested and examined. Any system and method for separating selected cells of interest from other cells and further separate the selected cells from one another, so that each can be separately tested and/or examined, would be of great significance in diagnosing various biological conditions and for other purposes. Testing and examining individual selected cells would eliminate errors, presently existing in many diagnoses, based on inexact statistical criteria.

The invention accordingly provides a method for selecting particular biological cells from other cells to facilitate the observation of at least one selected property of the selected biological cells, which method comprises substantially covering with cells, including the selected cells of interest, the upper surface of a substantially planar carrier of preselected thickness and defining upper and lower surfaces and comprising an ordered array of apertures therethrough, said apertures having a preselected configuration with preselected dimensions at the top and bottom surfaces, and said method including the step of washing the said upper surface of said carrier to remove cells not supported in said apertures whereby only selected cells of preselected dimensions are held substantially in said apertures with substantially one cell per aperture, characterised by providing the top dimension of each aperture larger than its

5  
10  
15  
20  
25  
30  
35  
40  
45  
50  
55  
60  
65

smallest internal cross-sectional dimension and both the thickness of said carrier and the top dimensions of each aperture of the order of the diameters of the selected cells, and the step of attracting any cell to the aperture in which it is to be supported, or of expelling any cell from the aperture in which it is supported, as a function of a known cell property. It will be appreciated that the method of the invention enables the precise location of a cell in a particular aperture to be identifiable, by the known position of the aperture with respect to coordinates on the x and y axes of said planar carrier.

The invention moreover provides an apparatus for selecting particular biological cells from other cells and observing at least one selected property of the selected biological cells, which apparatus comprises a substantially planar carrier of preselected thickness and defining upper and lower surfaces and comprising an ordered array of apertures therethrough, said apertures having a preselected configuration with preselected dimensions at the top and bottom surfaces, definable as top and bottom dimensions, respectively, whereby when the biological cells are disposed on said top surface, only selected cells of preselected dimensions are held substantially in said apertures with substantially one cell per aperture, characterised in that the top dimension of each aperture is larger than its smallest internal cross-sectional dimension and both the thickness of said carrier and the top dimensions of each aperture are of the order of the diameters of the selected cells, the precise locations of each aperture will be identifiable by its position with respect to coordinates on the x and y axes of said planar carrier.

It will be evident that cells of sizes smaller than those of the selected cells pass through the holes, while much larger cells cannot enter the holes. Once the carrier is rinsed, only selected cells are located in its holes, one cell per hole at a fixed address.

The cells in the carrier holes are then subjectable to biological tests and particular properties thereof are measured on a cell-by-cell basis, to determine which of the cells belong to a particular subgroup, based on their particular properties and their measured parameters. Once a subgroup of cells has been identified, since each cell thereof is at a known address, the addresses of all the subgroup cells are known. Thus, one can subject all the cells to one or more tests, but examine the properties of only each cell in the subgroup by directing the particular measuring and/or diagnosing instruments to the cell's unique address.

Further objects and features of the present invention will become more fully apparent from the following description of several embodiments of the invention based on the accompanying drawings, wherein:

Fig. 1A—1C are schematic illustrations, partly in sectional view, of preferred cell carriers of the invention;

Figs. 2A—2D illustrate one embodiment of a multiple cell carrier holder for carrying out measuring cycles at a plurality of cell carriers;

Figs. 3A and 3B are enlarged sectional views of the holder of FIG. 3;

Fig. 4 schematically exhibits an optical analyzer for scanning individually the cells of the population contained in a cell carrier;

Fig. 5 schematically shows a second embodiment of an optical analyzer;

Figs. 6A—6C exhibit modified holders of the embodiment of Fig. 3;

Figs. 7A and 7B show an embodiment of a flow chamber for the bottom side of an analyzing system;

Fig. 8 is a modified version of the flow chamber of Fig. 7;

Fig. 9 is again another embodiment of a holder and a flow chamber for an advanced analyzing system;

Fig. 10 is a separation unit adapted to receive the holder of Fig. 6 for providing the cell carriers with cells;

Fig. 11 is a sectional view of parts of the embodiment shown in Fig. 10;

Figs. 12A and 12B exhibit a separation unit adapted to receive the holder of Fig. 9 for providing the cell carriers with cells;

Figs. 13A—13C are details of a blood supply element adapted for use with the separation unit of Fig. 12;

Fig. 14 is a sectional view of another embodiment of a blood supply element adapted for use with the separation unit of Fig. 12;

Figs. 15A and 15B show an embodiment of a multi-carrier system for clinical use, wherein the separation and the measuring steps are combined;

Fig. 16 is a schematic overall illustration of an optical diagnosis system according to the invention; and

Fig. 17 illustrates a cell carrier for selectively attracting or releasing desired cells.

The invention will first be described, in a non-limiting way, with regard to selecting and analyzing a particular population of cells of a given type contained in a biological fluid from other populations of cells. In addition, a further selection of a special sub-population can be separated from the particular population selected. More specifically, the invention will first be described in connection with selecting and analyzing a particular sub-population of lymphocytes, which are present in human blood, by first separating the lymphocytes from other types of cells, and then testing the lymphocytes to identify the sub-population or subgroup within the group of lymphocytes.

L. Cercek and B. Cercek in articles published in European Journal of Cancer, vol. 17, 1981, pp. 167—171; same Journal vol 13, 1977, pp. 903—915; and in Biophysical Journal vol. 23, 1978, pp. 395—405 discuss the excitation and emission-polarization spectra of fluorescein in living cells (the article in the Biophysical Journal)

5

10

15

20

25

30

35

40

45

50

55

60

65

with relation to the application of the phenomenon of changes in the Structuredness of the Cytoplasmic Matrix (SCM) in the diagnosis of malignant disorders. Briefly, the Cerceks perform the so-called SCM test after first trying to separate a particular subgroup of lymphocytes from other lymphocytes, as well as, other types of cells by the density gradient technique.

This technique as previously pointed out is very unsatisfactory. First, it is very time consuming, as is appreciated by those familiar with the art, and as is clearly apparent from the articles by the Cerceks. Secondly, as the Cerceks acknowledge the finally separated cells do not belong to only the subgroup of interest, but include a large number, on the order of 50% of other lymphocytes. Thus, the analysis of their response to stimulation of the separated cells is very limited. Thirdly, and most significantly all of the stimulations and response measurements, performed by the Cerceks on the separated cells, are done on all the cells in a batch, rather than on a cell-by-cell basis. However, it is clear that a cell-by-cell analysis provides far more information for the understanding of biological implications of the phenomena under study.

The present invention makes it possible to realize such analyses very quickly, and accurately. In this particular case, both speed and accuracy are very important, considering the potential number of cancer diagnosis tests that one may wish to perform. Equally important, the novel invention, both in terms of the system and method, provides capabilities for separating biological cells from one another by placing each separated cell at a known address, to which one can return, for repeated cell observation and/or repeated stimulations followed by subsequent analysis.

Briefly, in accordance with the present invention a large number of cells, e.g. lymphocytes in the blood, which can be thought of as representing a group or population of cells are first separated from all other cells, i.e. from different groups or populations of cells. In the separation process the separated lymphocytes, in addition to being separated from the other cells, are also separated from one another, each being at a known location, hereafter also referred to as an address. All the separated lymphocytes are then subjected simultaneously to selected tests and thereafter each cell is separately investigated to determine whether or not, as a result of the test, or stimulation, it exhibits a particular property. The address of every cell exhibiting said property is recorded. Thus, after all the separated cells have been investigated the addresses of all the cells which exhibited the particular property are known. These cells represent a particular subgroup of lymphocytes within the larger entire group of lymphocytes. Once the cells in the subgroup have been identified, they together with the rest of the lymphocytes may be subjected to one or more additional tests. However, as to investigating the properties of the cells as a result

of these additional test(s) it can be limited to only the cells in the subgroup. Each cell in the subgroup is individually investigated by directing the investigative instrumentation to the cell's unique known location or address. Thus, once the cells in the subgroup have been identified only they are subsequently investigated, while all other cells, though belonging to the same group, but not being part of the subgroup, are ignored in that they are not subjected to any investigation. Consequently once the subgroup has been identified only its cells are investigated, thereby limiting investigation time only to the subgroup cells which are of interest. Also, since the investigation is done on a cell-by-cell basis, more precise data is obtainable for increased diagnosis accuracy. Other advantages of being able to identify cells of a subgroup and investigate each one individually will be discussed hereinafter.

As previously pointed out, in a first step the lymphocytes are separated from the other cells contained in the blood. The separation is performed by means of a perforated cell carrier 1 as shown in Fig. 1A.

The cell carrier 1 may have various configurations of apertures or holes 2, as well as the manner in which they are arranged. In Fig. 1A they are assumed to be arranged in rows and columns along axes X and Y, respectively. The holes are shown as having larger openings at the tops than at the bottoms thereof, as shown in Fig. 1B. In the presently described embodiment the holes are sized to be suited for receiving lymphocytes, among which there are two main sizes of about 7  $\mu\text{m}$  and about 10–15  $\mu\text{m}$ . At the upper surface or side 1t of carrier 1 the apertures have a cross-sectional dimension of approximately 10  $\mu\text{m}$ . The apertures at the bottom surface or side 1b have cross-sectional dimensions of approximately 6  $\mu\text{m}$ . The side walls of the apertures may converge continuously or in steps, as shown in Fig. 1C, towards the opening at the bottom side 1b of the cell carrier.

In general the aperture should be shaped so that either at its bottom side or at a cross-section intermediate sides 1t and 1b the cross-sectional dimension is less than at the top side, so that a desired cell entering an aperture does not pass through the aperture, but rather is held therein. Also it is important to close the carrier thickness between sides 1t and 1b so that the size of the aperture is related to the size of the desired cells so that when a desired cell enters an aperture practically the entire cell is within the aperture, thus preventing it from being washed out during a washing step, as will be described.

The shape of the apertures 2 enables the cells to be effectively held to the carrier by applying means, such as a pressure difference between the upper and the bottom side of the carrier, or electromagnetic forces. Briefly to first separate a particular group of cells from cells of other groups, since the cells in each group are of known size or sizes, which typically differ from those in other groups, the carrier 1 is chosen to have holes

of sizes so that the matter, e.g. blood, containing the various cell groups is placed on the carrier 1, effectively most if not all of the holes are occupied by cells of the group of interest, one cell per hole.

As previously pointed out, the holes 2 in carrier 1 are regularly arranged over or in the carrier, e.g. in rows and columns, to enable a clear identification of the position of every hole 2, for example, by its X and Y coordinates in the plane of the carrier. In the described embodiment the holes are disposed in rows and columns, extending perpendicularly to each other, thereby forming a matrix-like structure. The number of holes is chosen depending on the number of cells to be carried. For example, with 100 holes per row and column there is a total of 10,000 holes to carry 10,000 cells, on the carrier of the described embodiment, each with its unique position in X and Y. The carrier 1 itself may have a circular circumference, as can be seen from Fig. 6C. As shown therein the carrier has a plurality of ears 8, to align the carrier in a holder structure 40 which has a pair of indentations 9 extending from the top recess in which the carrier is supported. A hole extends axially about said recess in holder 40. Other aligning means such as pins or particularly shaped carriers are also within the scope of this invention.

The carrier 1 is made of any appropriate matter, e.g. metals such as copper, gold, nickel, silver or others, or of plastic, which may be provided with electrically conducting portions, extending between the holes 2 as shown in Fig. 17. Thus, the electric potential at any cell-containing hole can be influenced to produce an interaction with the cell's electrical charge. By controlling the potential at various holes the cells therein can be electrically bonded to the carrier as well as be released therefrom.

To practice the method a few drops of the solution containing the lymphocytes, e.g. blood, are dripped onto the cell carrier. The liquid passes through the holes in the carrier. However, the cells remain on the carrier. Since the sizes of the holes 2 are chosen to accommodate lymphocytes only, they enter the holes. Each hole accommodates only one cell. Excessive and other cells are washed off the surface of the carrier, such as cells of sizes so great that they cannot enter any hole, and/or excess cells more than the number of holes. Thereafter, in order to prevent the cells in the holes from leaving the carrier, they may be fixed thereto, by different means, e.g. by covering the carrier by an adhesive, colloidable matter, and by electrically charging it, as well as by electric and/or magnetic fields. Another combined method for isolating said population and simultaneously applying it to the carrier will be discussed later in connection with Figs. 10, 11, 12A and 12B.

Each carrier provided with its group of cells of interest, i.e. with lymphocytes, is placed in a carrier holder of a flow chamber such as holder 10 (Fig. 2D) to provide the necessary environment for the testing or measuring cycles, which will be described later.

In a first embodiment shown in Figs. 2A—2D, 3A

and 3B a plurality of matrices or cell carriers 1 are placed on holder 10 (Figs. 2D and 3A). Only one orientation of the carriers is possible so that the perforations (holes) of the carriers are aligned relative to defined axes, such as X and Y (see Fig. 1A). The holder 10 which is the top of the flow chamber, is removably mounted upon a central part 11 (Fig. 2A) of the flow chamber. The central part 11 defines a plurality of channels 12, each being connected at both ends to one of a plurality of tubes 13 for supplying and discharging a desired solution. The central part is fixed at its bottom by a lower part 14 (Fig. 2B) of the flow chamber comprising a transparent wall 15 which is necessary when using incident and transmitted light techniques for analyzing the cells on the carrier.

As can be seen from Fig. 3A, which is a view on a section perpendicular to the direction of a channel 12 (the solution therefore flowing "into the page"), a flow director 16 ensures that the solution contacts the cell carrier 1. In Fig. 3B a side view of this arrangement is illustrated schematically.

On the holder 10 the carriers 1 of several different individuals (patients) are placed in one row extending along the channels, while a column of carriers of the same person extend perpendicular to the channels. Each channel 12 is related to one type of test so that the number of tests to be run determines the number of channels 12 in the flow chamber.

Any solution, which flows through any one of the channels therefore wets all the cells in the carriers above that channel, each belonging to another patient. The cell carriers 1 may be covered by a glass plate 17 to make possible the use of immersion liquid for the optical scanning system, if necessary.

In Fig. 2A the flow chamber is shown comprising seven channels 12. In such a case cells from each patient are carried on seven carriers, one per channel, while along each channel are supported carriers with cells of different patients, as shown in Fig. 2D. Such an arrangement enables one to stimulate cells of different patients to different stimuli via each channel either simultaneously or successively and then test or analyze the response of each cell to the particular stimulus. Other embodiments to be described also comprise of a plurality of channels. Thus in each multi-channel embodiment the number of cell carrying carriers from each patient is typically equal to the number of channels. However, as will become apparent from the following description the invention is not limited to multichannel arrangements. It was found that cells after being stimulated by certain stimuli and examined can be cleansed and thus returned to their pre-stimulated state to be stimulated subsequently by a different stimulant. Consequently if desired only one cell-supporting carrier per patient can be used. The cells thereon can be successively stimulated and after each stimulation and analysis be rinsed for the next stimulation and analysis steps.

Now, before describing other embodiments of

5

10

15

20

25

30

35

40

45

50

55

60

65

5

flow chambers, it is considered desirable to describe particulars of one preferred method and system for individually analyzing the cells placed at defined locations on said carrier and introduced into said flow chamber. To this end reference is made again to the SCM-test as described by L. and B. Cercek et al. in the mentioned publications. According to L. and B. Cercek there are at least two characteristic properties of a subgroup of lymphocytes which are suitable for the SCM test. Acknowledgement of the specific antigen causes a lymphocyte to pass from a rest to a stimulated stage. When fluorescein molecules are imbedded in the lymphocytes, by utilizing a well known phenomenon, called fluorochromasia, the transition from the rest phase to the stimulated phase results in critical changes in the polarization of the fluorescence of the fluorescein in said lymphocytes. The lymphocytes, in which stimulation procedures may evoke such critical changes, differ in at least two characteristic properties from the other lymphocytes; the specific density, and the fact that for these cells a relatively high (control) value of fluorescence polarization is observed only for a very narrow band of the emission spectrum around 510 nm.

This second property is taken advantage of to mark out, or identify the proper lymphocytes among the whole population of lymphocytes and thus avoid the necessity of their physical separation. It is thus the group of lymphocytes which exhibits this particular spectral behaviour on which then all further stimulation effects are examined, while all other lymphocytes will henceforth be neglected by the evaluation technique of the system. Alternately stated, in accordance with the invention, first the carrier is used to separate lymphocytes in a person's drop of blood from other types of cells by means of the sizes of holes in the carrier. The holes are filled substantially by lymphocytes, one cell per hole. Smaller cells passing through the holes and larger cells are washed off the carrier's top surface. Thereafter the lymphocytes on the carrier are rinsed with FDA+PBS, which by fluorochromasia is converted within the cells to fluorescein. Then the fluorescence polarization within a narrow band of the emission spectrum around 510 nm from each cell, is measured and recorded. Only those lymphocyte cells, each of which exhibits a relatively high value of fluorescence polarization, definable as P are regarded as belonging to the particular subgroup of interest. Since the address of each cell on the carrier hole array is known the address of each cell in the subgroup is known. Thus once the cells belonging to the subgroup are known, all subsequent measurements and/or observations which may be performed, are performed only on the cells in the subgroup, whereas all the other lymphocyte cells on the carrier which do not belong to the subgroup may be ignored in that neither measurements nor observations are performed on any of them. The limiting of subsequent measurements or observations to only the

cells in the subgroup greatly reduces analysis time which is of great significance. Furthermore and possibly more important, since the address of each cell is known, the cell's unique response to each stimulant can be recorded to provide unique information, heretofore unattainable due to the fact that measurements and observations were performed on batches of cells or those employing flow systems. Also even when observing a particular cell under a microscope one could not thereafter stimulate it with another stimulant and observe the cell's response thereto. This is due to the fact that heretofore individual cells were not placed in a fixed array with the address of each cell known, so that the measurement and/or observation instrumentation could be directed repeatedly to the same address to observe the same cell.

A suitable criterion may be determined, of the minimum ratio of polarizations measured at two fluorescence emission wavelengths, namely 510 nm and at 515 nm. Therefore, as a first step, the cells of the critical subgroup of lymphocytes are identified by testing said criterion for every single cell on the carrier. Upon transition to a state of stimulation the degree of polarization of the stimulated members of said subgroup decreases to a value of about 0.14 for said emission wavelength of 510 nm. This change of the degree of polarization is examined only for the identified cells of said subgroup.

A system for carrying out these tests for each cell on the carrier will now be described in connection with Fig. 4. The cells on carrier 1 are first typically rinsed with a solution of phosphate-buffered saline (PBS) and fluorescein diacetate (FDA). The latter due to the phenomenon of fluorochromasia is converted within each lymphocyte cell to fluorescein. Then the fluorescein is excited by radiation of wavelength 470 nm upon which it emits its characteristic emission spectrum. The determination of which of the lymphocyte cells on the carrier belong to the subgroup of interest is made by stepwisely scanning each and every cell on the carrier by means of the optical analyzer 20, shown in Fig. 4.

It includes a zirconium lamp (or laser) 21 which serves as a light source peaking at 470.1 nm and 468 nm, thus eliminating the need for an excitation filter to filter any light in the range of interest, i.e. 510 nm and 515 nm. The light is plane polarized perpendicular to the plane of Fig. 4 by a polarizer 22, after passing a focusing lens 21a. The plane polarization is represented by the small circles. The plane polarized light beam strikes a mirror 23 which acts as a beam splitter in that it transmits light of  $\lambda > 500$  nm and reflects light below such wavelength. Thus the light from source 21 is reflected to the carrier 1, through a lens 24.

The fluorescence emitted by each cell on the carrier is separately measured and recorded. The fluorescence from a cell passes through mirror 23 and lens 24a to a Glenn-Thompson polarizer 25. Basically, polarizer 25 divides the fluorescence

5

10

15

20

25

30

35

40

45

50

55

60

65

into two parts: One polarized parallel to the plane of the paper (indicated by the dashes in Fig. 4) which proceeds at the original direction of incidence, and the other polarized normally to the plane of the paper (indicated by the circles in Fig. 4) which is deflected normally to the direction of incidence. Each of the polarized beams is divided into two equal and perpendicular beams by a beam splitter (26, 27). Each of these four newly formed beams passes through an interference filter of 510 nm or 515 nm (28, 29, 28', 29' respectively) and their intensities are measured simultaneously by four photo multiplier tubes (30, 31).

These four measured intensities are stored in a computer system such as that shown in Fig. 16, and the degree of polarization for each wavelength, i.e.  $\lambda=510$  nm and  $\lambda=515$  nm is calculated. The degree of polarization is defined as

$$P = \frac{I_{||} - I_{\perp}}{I_{||} + I_{\perp}}$$

After calculation of  $P_{510}$  and  $P_{515}$  their ratio, i.e.  $P_{510}/P_{515}$  representing the control value is calculated in real time. The address of each cell in terms of its X and Y coordinates are known and is stored together with its control value. After all the cells have been examined and their control values determined and stored it is very simple to determine the cells having a control value of not less than 1.3. It is these cells that belong to the subgroup of interest. Once this determination is made all subsequent measurements or observations of the response of the cells to various stimulating agents are performed on the cells in the subgroup only and all other cells are ignored. For example only the cells in the subgroup are reexamined to determine which of them exhibit a change in the degree of polarization sufficient to identify them as active and thus capable of identifying a particular antigen.

It should be apparent that to test each cell individually the optical analyzer 20 (Fig. 4) has to have an optical resolution in the range of one cell diameter which is achievable with a microscope objective. The carrier with the cells is stepwise displaced under the microscope from one perforation to the neighboring one. A precise mechanical displacing system, as described in Fig. 16 is thus necessary.

In another embodiment of the optical analyzer, the need to stepwise displace the cell carrier is avoided by using a laser as excitation light source. In Fig. 5 this embodiment is schematically illustrated. A laser beam 131 of appropriate wavelength passes through a controlled deflecting optical element such as, e.g., a rotating mirror 130. The laser beam 131 has a cross-section which corresponds substantially to the size of a cell. By means of the deflecting element 130 the beam 131 scans the cells in the holes sequentially, thereby exciting each cell, one after the other. At any given time only one cell is hit by the laser beam and therefore only this cell emits fluorescence light at that moment. The optical analyzer 131x, disposed on the other side of the carrier 1

has a visual field, covering the whole surface of the carrier 1. The moment of the receipt of an emission signal is the intensity of this signal correlated with the position of the scanning laser beam 131, hence each received and analyzed light signal is correlated with the position of the respective cell from which it has been emitted. As can be seen from Fig. 5 the excitation is made from the large side of the holes 2 in the carrier 1. For the optical analysis, on the other hand, emission light leaving each hole through the narrow end is preferably used for reasons which will be explained below.

Having explained preferred analyzing systems using the invention, it should be well understood that analogous systems for measuring other parameters may be used, provided that focusing on each single cell on the carrier is possible. Examples of measurable parameters include light intensity, optical density, index of refraction, electromagnetic properties, absorption and scattering. Furthermore, the scanning procedure is not limited to beams such as visible light, U.V., I.R. and electron optical systems, but may also include probing via physical contact at each cell. Other examples of measurable or observable properties include nuclear magnetic resonance (NMR), pH value as well as cell morphology and changes thereof in response to different stimulants. For example, one can direct the output of a microscope pointed at any cell to a pattern recorder to produce a two-dimensional record of the cell's pattern. Cell temperature measurements and/or temperature changes may be performed and recorded. In summary, any one or more measurable or observable property of a cell may be performed on a cell by cell basis. Since the address of each cell is known one can always return to the same cell for additional measurements and or observations. All measurements and observations for each cell can be recorded to obtain unique information for each individual cell. This information can be correlated to provide insight and diagnosis, heretofore unattainable.

An embodiment of the invention for practical clinical use will now be explained in connection with Figs. 6A—6C which show a modified holder 40 for a plurality of cell carriers 1. The holder 40 is wave-formed to enable its troughs 41 to be immersed in the solutions flowing through the channels 12 at a higher level. The cell carriers which are mounted on the bottom of the troughs 41, can be wetted to rinse or otherwise stimulate the cells both from the upper and the bottom sides. Therefore, in this embodiment there is no need for flow directors, as previously explained in connection with Figs. 2A, 3B. As has been described in connection with Figs. 2A—2D, the cell carriers positioned on the same trough 41 belong to different patients. In spite of this there is no danger of any mixed lymphocyte stimulation effect because there is no physical connection between carriers. Even if a cell would disconnect from one carrier, the chances of it being rinsed

5

10

15

20

25

30

35

40

45

50

55

60

65

out are much higher than that of it being deposited on another carrier. In Fig. 6A carriers are shown only in one trough. However in practice for each patient a carrier is present in each trough.

In Fig. 6C the carrier 1 is shown as being removable from holder 40. However to define its hole array in X and Y, it includes ears 8 locatable in indentations 9.

Since the cell carriers 1 of the present embodiment are immersed in the solution flowing through each channel 12, the microscope of the optical system for cell scanning is provided with a quartz sleeve 42 (Fig. 6B) dressed on its objective cylinder. The channels 12 and the troughs 41 have dimensions which enable the relative movements of the objective and the carriers necessary for scanning the whole surface of each of the carriers.

As indicated above, to select the subgroup of cells based on the above described control value the channels are first supplied with a PBS+FDA solution during the control measuring cycle for identifying the proper cells on each carrier belonging to the subgroup. Thereafter, for determining the reaction of the selected cells to different stimulating agents each channel is supplied by a different stimulating agent, e.g. phytohemagglutinin (PHA), EF, CaBP, tumor extracts, or any other desired mitogen or antigen. Then the responses of only the selected cells are examined and recorded.

For the above stimulators it was discovered that stimulation of cells by one stimulator, does not affect any following stimulation if the stimulator is rinsed and/or neutralized before the next stimulation test, in order to prevent any direct interaction or any competitive effect between them. Furthermore, it has been found that bonding the cells to the carrier has no effect on their activation. As a consequence, the stimulation procedures can be repeated on the same cell at the same location on the carrier, and this with different activating agents. Thus, an exact profile of the response of each individual cell of the subgroup to activation can be received as a function of time and it is therefore now possible to know the exact number and response of the activated cells and their places on the matrix which remains the same during and after the above described measuring cycles.

Most of the carrier holder systems, described above, were designed for top scanning, i.e., for analyzing the emitted fluorescence light from the large upper side of the holes in the carrier, which allows the use of the same optical system for optical examination and analysis of the cells. In alternative embodiments, which will be described herebelow, the optical analyzer is placed to receive the emission light passing through the narrow side or bottom of the holes 2. Thus, disturbing effects, caused by light emission of fluorescein, which leaks out of the cells and is present in their surroundings can be eliminated. The light emitted by the surrounding fluorescein represents an undesired optical background.

Looking at the cells from the narrow sides or bottoms of the holes permits the reduction of this background substantially, since the narrowing conus acts as a shield against undesired emission light. Moreover, in the case of the excitation light entering the holes through their large sides, or tops, reflections at the conical walls may occur, whereby incident light as well as fluorescence light is reflected back. Another advantageous effect, caused by carrying out the optical analysis in the mentioned way is that at every location on the carrier only the emission light of the cell trapped within the respective hole is received, whereas other cells which may in exceptional cases be present at the upper surface of the carrier do not influence the measuring results. Still another advantage resides in the fact that due to the smaller size of the openings it is much easier in practice to analyze the emission light of each cell separately, without the danger of cross-talking between adjacent cells if the adjusting mechanism of the optical system relative to the holes is not of extreme precision.

By means of the Figs. 7A, 7B, 8 and 9, various embodiments are illustrated which enable the optical analysis to be carried out as explained above. In a first embodiment for use with a microscope optical analyzer (Figs. 7A and 7B) the bottom wall 110 of the flow chamber comprises elastic (rubber) glass holders 111, each carrying a glass plate 112 adjusted relative to an above located cell carrier 1. The elastic glass holder 111 provides a fluid-tight seal between the glass plate 112 and the bottom wall 110 of the flow chamber and enables the objective 113 of a microscope to be moved close enough to the cell carrier 1 for scanning its individual locations or holes from below (Fig. 7B). If the objective 113 of the microscope is in its lower position, the channel of the flow chamber then is opened to its initial width. In a modification (Fig. 8) of this embodiment, the bottom and side walls of the flow chamber are integrally made of rubber.

In a second embodiment (Fig. 9) the optical analysis is made from the upper side. However, the holder 114 for the cell carriers 1 is placed upside-down on a bottom portion 115 of the flow chamber, after being provided with cells in a special unit (which will be described in connection with Figs. 12A and 12B, such that the conical holes in the carriers 1 flare downwardly. In order to hold the cells in place and to effectively bond them to the carrier a pressure difference is applied between the bottom portion 115 (fig. 9) and an upper portion 116 of the flow chamber, the fluid in the bottom portion 115 having a slightly higher pressure than in the upper portion 116. Sealing ledges 117 prevent the two portions of the flow chamber from leaking. Using this embodiment the optical analyzer of Fig. 4 can be used for scanning the cells on carriers 1 without giving up the above-described advantages.

Returning now to the problem of providing the cell carriers with cells of a certain desired population or group, which in principle could be done in

5

10

15

20

25

30

35

40

45

50

55

60

65



substantially conventional manner as described before, Figs. 6, 7A and 7B illustrate a system for simultaneously separating said cell population from other groups of cells other than by the conventional disadvantageous methods of cell separation. The present embodiment is also described with regard to the separation of lymphocytes from the other blood cells, for use in the above described SCM-tests.

As can be seen from Fig. 10 and Fig. 11 the holder 50, which is insertable onto the flow chamber of Fig. 6A rests on an arrangement of pipes 51, each being subdivided lengthwise in an upper part 53 and a lower part 52. The lower part 52 forms a fluid (air or liquid) conduit of lower pressure to drain liquids and improper blood cells from the upper part 53. The upper part comprises bridges 54, under which there are drainage holes 55, and between which there are suction holes 56, aligned with the carriers 1 on the holder 50. In Fig. 10 carriers for supporting cells from only one patient are shown. The upper and the lower parts 53 and 52 are supplied by a fluid, say a PBS-solution. As becomes clear from the sectional view of Fig. 11, the fluid in the upper part passes under the bridges 54 and through appropriate slots 57 in the holder 50. The fluid in the lower part 52 is forced by projections 58 to flow with a higher speed in the region of the draining holes 55 and the suction holes 56, thereby creating a local subpressure in these holes. Therefore the fluid initially flowing through the upper part 53 is partly drawn to the lower part through said holes.

A blood supply element 60, removably placed upon the holder 50, is provided for supplying the carriers 1 with blood. Legs 61 of supply element 60 prevent fluid from passing from one row of slots 57 in the holder 50 to another.

As a theoretical basis for understanding the cell separation by the above unit, the following facts are emphasized:

- a) the size of the responding lymphocytes is  $\sim 7 \mu$ .
- b) the size of macrophages, granulocytes is  $\sim 20 \mu - 35 \mu$ ;
- c) the size of erythrocytes can reach  $3 \mu - 5 \mu$ ;
- d) there are large lymphocytes— $15 \mu$ ;
- e) the size of the platelets—negligible;
- f) cells can burst when left in distilled water;
- g) the life span of an erythrocyte in distilled water is much less than that of a lymphocyte.

The cell carrier holder 50 is first placed on the pipe arrangement, such that the carriers of the first row (normal to the channels) are placed above the holes. The supply element 60 is placed with its legs 61 being on either side of the cell carriers. The whole system is assembled, as shown in Fig. 11. A syringe with full blood from a patient is placed in a syringe holder 62. In Fig. 11 two such holders are shown for two different patients. The blood flow in each of the pipes is controlled by applying suitable pressure on the syringe. Blood arrives at all the exits of pipes P1 and P2 (from 2 different patients) after the first few pressure pulses.

At a certain stage a pressure pulse will cause a drop of blood to fall on each cell carrier. The size of the holes in the carrier will not allow the blood to pass from one side of the cell carrier to the other. To this end a sub-pressure is formed in the lower half of the separation pipe, as described above, by running PBS through this part of the pipe. The blood is sucked immediately under the carrier.

The smaller cells will pass through the carrier and will be rinsed away with the PBS flow. Those with a size similar to that of the top of the holes of the carrier, e.g.  $7 \mu$ m, will stop on the carrier and the biggest will rest above carrier. In order to prevent blocking of the carrier, the blood supply is stopped and PBS flows across the upper part of the matrix for washing away the bigger cells. Most of them are sucked into the drainage holes 55 (Fig. 11). The minority of the cells get to the next carrier (in the direction of the stream) and pass out. As previously pointed out, all cell carriers, placed perpendicularly to the extension of the channels are filled with the blood of one donor. Therefore there is no problem of blood being mixed from different donors.

In a next stage the upper flow is stopped and another drop of blood is dripped and the cycle is repeated as often as necessary. After a few drops of blood a so-called "upper bursting wash" is carried out. The process is continued until the carrier is sufficiently filled. A rough test of this can be made by testing the electrical resistivity of the carrier after each drop. Distilled water flows for any desired time and causes the erythrocytes to burst. The distilled water causes cells to swell, and therefore, the erythrocytes burst, while the lymphocytes strengthen their hold in the carrier holes. At the end of the desired time interval PBS is introduced. The substances set free from the bursted erythrocytes cannot influence the lymphocytes since there is a permanent flow of solution washing these substances away electrically charging or recharging the matrix, or applying or terminating electromagnetic fields is analogous to vibrating the matrix via ultrasonic or other techniques which can also be used. This procedure can be added and correlated with the stages of washing. Less than 1 cc. of blood will be necessary from each patient P<sub>1</sub>, P<sub>2</sub>, etc.

This separation process lasts about 5 minutes at the most. There is no limit to the number of blood samples from which cells can be simultaneously separated. The holder 50 is then removed from the separating system and inserted into the flow chamber of Fig. 4 for the optical scanning operation as described above.

A similar separating system but adapted to the holder 114 of Fig. 9 will be explained by means of Figs. 12A and 12B. A base plate 120 is provided with channels 121 for fluid flow, causing the necessary local subpressure in the region beneath the carriers 1 and draining holes 55. To this end projections 122 are formed on the base of the channels 121. The holder 114 is removably placed on the base plate 120 so that its carriers 1

5

10

15

20

25

30

35

40

45

50

55

60

65

are aligned with the projections 122 as can be seen from Fig. 12B, such that their conical holes open upwardly, i.e. towards an overlying removable supply element 123 which is similar in function to the supply element 60 of Fig. 10. The supply element 123 may supply the cell carriers with cells merely by the action of pressure as has been explained in connection with Fig. 10. It is, however, possible to enhance the efficiency of blood supply by providing smearing elements which are displaceable with respect to the carriers, as illustrated in the Figs. 13A, 13B, 13C and 14. In Figs. 13A, 13B and 13C an embodiment is shown, having slide plates 124 extending in the supply element 123 aligned with the channels 121.

At each outlet of a supply conduit a resilient smearing element 125 is arranged as can be seen from Figs. 13B and 13C. In Fig. 13B a cross-section of the smearing element 125, perpendicular to the direction of a slide plate 124 is shown, whereas Fig. 13C illustrates a cross-section along the extension of said plate 124. The width of the resilient smearing element 125 substantially correspond to the side length of a carrier and it forms a small outlet for linearly sweeping over the carrier surface, when moving the slide plate 124, such that each carrier is coated by a thin layer of cells. Thereafter the above described washing steps are performed.

In Fig. 14 another embodiment of the smearing element is shown in a cross-section, perpendicular to a channel 121. In a swivelling bar 126 extending along each channel 121 a blood conduit 127 is formed, which at each carrier 1, is provided with an outlet, having a distributing brush 128. When supplying blood to the carrier, the swivelling bar 126 is swivelled several times, thereby brushing the cells onto the carrier 1.

While in the above embodiment blood supply and "rough" separation is performed by means of a special separation unit whereafter the holders 40, 50 and 114, respectively, have to be placed on a flow chamber for optical scanning, in some cases it may be desirable to eliminate this step. In a further embodiment of the invention which is shown in Figs. 15A and 15B the cell separation and the optical scanning operation are therefore combined in one apparatus.

A supporting system 70 is provided with surface channels 71, 72 extending transversely to each other and inner conduits 73, 74 also extending transversely to each other. At every junction a carrier 1 is arranged on a rotatable holder 75, a section of which is shown in Fig. 15B. At its base a pinion 76 is formed which cooperates with a respective rack 77, extending through the supporting member 70. One rack 77 drives all the holders 75 of the respective column. Linear movement of this rack 77 causes rotation of the holders 75. The direction of introducing blood for rough separation, i.e., for separating the group of lymphocytes from the other group of blood cells, is perpendicular to the plane in which the cell carrier is scanned under the microscope. Thus, after

separation of the lymphocytes from other blood cells the holders 75 are rotated 90° for the scanning operation.

In order to make possible the technique of "transmitted light" (measuring light exiting the bottom end of a hole) in the above embodiment, the portion of the channel which crosses the holder 75 under the cell carriers is a pipe of glass 78 which is divided lengthwise. This pipe is arranged so that its open side is directed towards the carrier (see Fig. 15B). In this way horizontal liquid flow through the holder is made possible, while at the same time light is transmitted in a vertical direction. The subpressure in this system is caused by making the inner conduits 73, 74 closed and thinner, while the upper channels 71, 72 are wider and open. The same effect can be achieved by other techniques, such as increasing the flow rate in the inner conduits with respect to that of the upper channels.

The procedure can be summarized as follows: With the aid of a 0—90° controller the position of the holders 75 is determined. In a first stage, when the "rough separation" is carried out, the channels 71 and conduits 73 are in operation. Upon completion of this stage, the holders 75 are rotated by 90°. Thus the channels 71 and conduits 73 are blocked or closed and the channels 72 and conduits 74 are opened.

In this embodiment a blood drip-head may be attached to the scanning head, e.g. microscope. Then in response to command signals from a controller, e.g. a computer the separation and the optical scanning are performed automatically and without need for a trained operator. The operator need only place the syringes, as shown in Fig. 6 and to change the holders 75, after completion of the tests.

In Fig. 16 to which attention is directed, an overall system of cell separation, scanning and analysis (diagnosis) is shown. A flow chamber 81, as described above, is mounted on a table 82 which is displaceable in three axes X, Y, Z by respective computer controlled step motors 83, 84, 85. The optical system includes a microscope 86 with an optical analyzer 87, as described in Fig. 4. An excitation light source 88, e.g. a zirconium lamp, uses the same optical system in reverse direction. In a solution tank 89 all the solutions necessary for cell separation and testing are stored. By a solution control unit 90 the supply of the respective solution is controlled. In order to stabilize the fluorescein concentration in the cells, which may influence the absolute polarization values, an electro-optical mechanical feedback control is used, wherein the intensity of the fluorescence emission light is periodically measured and compared with a reference value. Any deviation of the measured value from the reference value may be used to cause a change in the concentration of FDA in the PBS solution. The analysis of the measured value may be carried out by any well known computer system. A precomputer interface 91 serves to transform the measured values into computer-readable infor-

5

10

15

20

25

30

35

40

45

50

55

60

65

mation which is typically digital. In a computer 92 the necessary calculations and identification steps are performed and stored in a memory 93. A post computer controller 94 generates the control signals for the step motors and the solution control unit.

The operation of the above system may be summarized as follows: After the rough separation procedure, the flow chamber is fixed on the table 82. The microscope is adjusted. Henceforth the test proceeds automatically. A PBS+FDA solution is introduced through the channels and conduits. Part of it penetrates through the carriers from the upper channels to the lower conduits and part of it continues to flow through the upper channels, washing the cells from above. After a chosen pause, e.g. 20 minutes, the scan begins. The polarization of every single cell is measured at the desired wavelengths. There is no danger of over-exposure of the cell to the exciting light, e.g. 470 nm, because scanning is performed very rapidly.

The optical information—after conversion into an electric current pulse—is fed into the computer, evaluated and stored in the memory. Every single cell is identified in the memory according to its coordinates, i.e. address on the carrier. From this stage on, everything that can be learned about each single cell will be stored in the computer relating to its address.

The collection of data may be summarized as follows: The control values of cells of all patients whose carriers are aligned in one channel will first be determined. Then the scanning head will be transferred to the next channel (by lowering the table and moving it aside) and will be used in the determination of the control values of all the cells on the carriers aligned in the second channel. Simultaneously with the data collection from the second channel a stimulating solution will be introduced into the first channel. Upon termination of the data collection from the second channel the scanning head is transferred to the third channel and a second stimulating solution is introduced into the second channel etc.

After data collection from all the carriers the scanning head will be returned to its first position. Then the scanning operation is repeated on the stimulated cells. This time the data collection will be selective and only cells which meet the described optical criterion, i.e. those belonging to the particular subgroup, will be reread. Therefore, the information which will be accumulated in the computer will be cell position, control values, values of polarization after stimulation with PHA, values of polarization after stimulation with CaBP, SCM-response ratio, (See L. Cercek et al. in *Europ. J. Cancer*, Vol. 17, pp. 167—171, 1981), polarization values after stimulation with specific tumor stimulators, and the like.

The distinction between the cell carriers of different patients may be made by magnetic or optical coding which can be fixed on the holders during the rough separation stage. A magnetic or optic reader can be attached to the optical scan-

ning head which will read the patient's code and transfer it to the computer. All the information pertaining to each patient may be transferred to a predetermined place in the computer memory.

By this system the exact number of activated lymphocytes can be determined for every stimulating agent. To one familiar with the art, the present invention permits cancer diagnosis at a very early stage. Although the present invention has been described primarily in conjunction with cancer diagnosis it is obvious that the inventive method and system are not limited thereto. Generically they provide a method and means for rapidly conducting biological assays leading to new clinical diagnosis and treatment as well as to new applications in the field of biotechnology and bioengineering.

As mentioned above, the exact position of each activated cell on a carrier is determined and stored. Therefore it is possible to isolate a desired group or subgroup of cells on the carrier by selectively removing all other cells from the carrier, so that only the subgroup of cells remains thereon, or by releasing and removing only the cells of the subgroup from the carrier. To this end use may be made of the known fact that cells are not electrically neutral but possess electrical surface charges. This fact may be used in the above described embodiments for bonding or otherwise securing the cells to the carrier. The same effect may be used to selectively release or hold desired cells. This may be achieved by a modified embodiment of the cell carrier of Fig. 1A, which will be now be explained in connection with Fig. 17. The outer shape of the carrier 100 is the same as shown in Fig. 1A. However, carrier 100 is provided with electrical conductors 101 extending between the holes 102 in grid-like configuration and being electrically isolated from each other. At the periphery of the carrier the conductors are connected in a known manner (IC-technique) to a computer controlled switching arrangement for selectively influencing the electrical potential of every conductor 101. For securing the cells to the carrier all conductors 101 may be held at the same potential opposite the cells' charge potential, resulting in electrical attraction of the cells. For releasing any cell, say the one in the hole marked A in Fig. 17, the neighboring conductors  $V_{x2}$ ,  $V_{x3}$ ,  $V_{y1}$ ,  $V_{y2}$  may be set to an appropriate potential to cause the ejection of the cell in hole A from the carrier.

The cell carrier 100 may be produced by a multilayer technique, known from IC-production. In case an ionic solution, such as PBS, is used, measures should be taken to avoid undesired influences of possible surface charges on the holder. For this purpose it may be isolatedly coated and provided with conducting elements ending in the channel. This would cause ions to be attracted and neutralized, thus preventing the formation of an ion cover over the holder surface which may affect the potential of the carrier. Another possibility is to use non-ionic, organic solutions such as lipids for flowing the carrier in this stage of the procedure.

The separation of particular cells in accordance with the invention from all other cells is uniquely applicable in the field of clinical treatment in the production of clones. Clones may be produced from particular cells which were selected from other cells in accordance with the present invention based on any chosen property. For example, it is well known that the body of a person, afflicted with certain diseases, e.g. skin cancer, produces identifiable cells to combat or kill the disease. However to be successful, a large number of such cells, hereafter referred to as killer cells, may have to be present in the body. With the present invention, blood, lymph nodes and different body tissue, containing some killer cells, may be used as the source of such cells. After separating them, as heretofore described, from all other cells, the killer cells may be multiplied by appropriate cell growing techniques, and then introduced into the patient, from which the original cells were received to fight the disease. In such a case, no cell rejection is expected since the cells originated from the patient's body. Thus, the present invention can be used to provide a person's body with enough cells to fight its own affliction.

It should be pointed out that whereas heretofore the separation between cells of interest on the carrier and other cells can be accomplished by expelling or removing either the cells of interest from the carrier so that only the other cells remain on it, or by removing the cells which are not of interest and leaving only the selected cells on the carrier, if desired one can produce such separation by destroying such as by killing the cells which are not of interest while they are in apertures of the carrier so that the only live cells remaining on the carrier are the cells of interest. The killing of cells in the apertures, i.e. in-situ may be achieved by directing a laser beam to each cell at its known address as well as by similar or analogous means. A killed cell, i.e. a dead cell even though on the carrier can thus be regarded as being separated or removed therefrom since for all practical purposes, once killed it is disregarded. As used herein the term "expelling" of a cell is intended to include removing a cell from the carrier or killing it in-situ.

As to multiplying cells of interest it should thus be apparent that it can be done after:

- a) the cells to be multiplied were removed from the carrier bearing live cells which are not of interest on it;
- b) removing the cells which are not of interest from the carrier and thereafter multiplying the cells of interest for growth purposes; and
- c) killing the cells which are not of interest when they are still in the apertures and multiplying the cells of interest in-situ, i.e. while they are in their apertures of the carrier.

While the principles of the invention have been described in connection with specific systems, applications and methods, it is to be understood that this description is provided for explanatory purposes only and is not intended as a limitation of the scope of the invention.

Many new applications in biological research, clinical treatment and industrial production are opened by the present invention. It is expected, and has been established to a satisfactory extent, that there are optical parameters related to the cyclic phase of the cells. By this invention it is possible to differentiate a cell population according to the cells' age, their cycle stage and their inherent function, and to conduct respective examinations. A clinical application of the above resides in early detection of leukemia which is characterized by the presence of a high number of young cells of a certain type or types in the blood, and in the bone marrow.

As another clinical application immunoreactivity tests for organ transplantations may be performed. To this end a preparation of the transplant is used as stimulating agent in the invention.

A general and major feature and advantage of the invention is the fact that the time required for biological experiments and tests is substantially shortened since cell identification and testing is carried out in a substantially shorter time than in conventional biological methods wherein natural developments often have to be reproduced under artificial conditions, leading to uncertain results, necessitating extensive statistical evaluations. The invention reduces the influences of the surroundings allowing numerical analysis with a minimum of statistics. The time requirement to perform measurements with the present invention is very short in absolute terms as compared to the prior art, thereby reducing the effect of changes in the environmental conditions of the surroundings, such as temperature, humidity, etc.

Although particular embodiments of the invention have been described as illustrated herein, it is recognized that modifications and variations may readily occur to those skilled in the art and consequently, it is intended that the claims be interpreted to cover such modifications and equivalents.

#### Claims

1. Apparatus for selecting particular biological cells from other cells and observing at least one selected property of the selected biological cells, which apparatus comprises a substantially planar carrier (1) of preselected thickness and defining upper and lower surfaces and comprising an ordered array of apertures (2) therethrough, said apertures having a preselected configuration with preselected dimensions at the top and bottom surfaces, definable as top and bottom dimensions, respectively, whereby when the biological cells are disposed on said top surface, only selected cells of preselected dimensions are held substantially in said apertures with substantially one cell per aperture, characterised in that, the top dimension of each aperture is larger than its smallest internal cross-sectional dimension and both the thickness of said carrier and the top dimensions of each aperture of the order of the

5

10

15

20

25

30

35

40

45

50

55

60

65

diameters of the selected cells.

2. Apparatus according to claim 1 wherein the top and bottom dimensions of each aperture are in the range of micrometers.

3. Apparatus according to claim 1 wherein the apertures are dimensioned to hold lymphocytes, one per aperture.

4. Apparatus according to any of claims 1 to 3, in which the precise location of each aperture is identifiable by its position with respect to coordinates on the x and y axes of said planar carrier.

5. Apparatus according to any of the preceding claims, which further includes first structure means (10;4 0) for supporting said carrier at a defined location thereon, whereby each aperture of said carrier is located at a known location, definable as an address, with respect to said structure means, instrument means (Figures 4, 5, 6B) for observing and/or measuring at least one cell property, and control means (94) for controlling the relative movement and operation of said instrument means with respect to said carrier, and thereby enabling the observation and/or measurement of at least one cell property of a cell in any particular one of said apertures, based on its address, to be effected.

6. Apparatus according to claim 5 wherein said instrument means comprises optical scanning means (86, 87) for determining optical properties of any of said cells.

7. Apparatus according to claim 5 wherein said first structure means (10) includes means for supporting a plurality of spaced-apart carriers, each carrier having cells in its apertures, and second structure means (11) selectively positionable relative to said first structure means, for enabling the cells on each of said spaced-apart carriers to be simultaneously stimulated by preselected matter, with said control means (94) being adapted to direct the relative movement of said instrument means with respect to any one of said carriers, and thereby enabling the observation and/or measurement of at least one cell property of a cell in any particular one of said apertures, based on its address, to be effected.

8. Apparatus according to claim 7 wherein said first and second structure means are positionable with respect to one another, whereby said cells are stimlatable by being wetted through either the top or bottom end of said apertures.

9. Apparatus according to claim 7 wherein said second structure means includes means for containing different stimulating matters therein, whereby cells in at least some of the apertures of said spaced-apart carriers may be stimulated simultaneously by said different stimulating matters.

10. Apparatus according to any of claims 1 to 6, and including also force producing means for attracting or expelling any of said cells to or from the apertures.

11. Apparatus according to claim 10 wherein said force producing means comprises means arranged in a predetermined pattern with respect to said apertures for attracting or expelling one or

more of said cells to or from the apertures by electromagnetic means (101).

12. Apparatus according to claim 10 wherein said force producing means comprises means (Figure 11) for producing a pressure difference across at least a selected portion of said carrier(s).

13. Apparatus according to claim 10 wherein said force producing means comprises means (115, 116, 117) for enhancing the adherence of the cells in said apertures.

14. Apparatus according to any of claims 10 to 13, wherein said first structure means (10) includes means for supporting a plurality of spaced-apart carriers, each carrier having cells in its apertures, and second structure means (11) selectively positionable relative to said first structure means, for enabling the cells on each of said spaced-apart carriers to be simultaneously stimulated by preselected matter, with said control means (94) being adapted to direct the relative movement of said instrument means with respect to any one of said carriers, and thereby enabling the observation and/or measurement of at least one cell property of a cell in any particular one of said apertures, based on its address, to be effected.

15. Apparatus according to claim 14 wherein said first and second structure means are positionable with respect to one another, whereby said cells are stimlatable by being wetted through either the top or bottom end of said apertures.

16. Apparatus according to claim 14 wherein said second structure means includes means for containing different stimulating matters therein, whereby cells in at least some of the apertures of said spaced-apart carriers may be stimulated simultaneously by said different stimulating matters.

17. A method for selecting particular biological cells from other cells to facilitate the observation of at least one selected property of the selected biological cells, which method comprises substantially covering with cells, including the selected cells of interest, the upper surface of a substantially planar carrier of preselected thickness and defining upper and lower surfaces and comprising an ordered array of apertures there-through, said apertures having a preselected configuration with preselected dimensions at the top and bottom surfaces, and said method including the step of washing the said upper surface of said carrier to remove cells not supported in said apertures whereby only selected cells of preselected dimensions are held substantially in said apertures with substantially one cell per aperture characterised by providing the top dimension of each aperture larger than its smallest internal cross-sectional dimension and both the thickness of said carrier and the top dimensions of each aperture of the order of the diameters of the selected cells, and the step of attracting any cell to the aperture in which it is to be supported, or of expelling any cell from the aperture in which it is supported, as a function of a known cell property.

5

10

15

20

25

30

35

40

45

50

55

60

65

18. A method according to claim 17 which further includes the step of treating the cells in the carrier apertures following a prior stimulation substantially to return them to their prior state.

19. A method according to claim 18 which further includes the steps of neutralizing the cells in the carrier apertures following a prior stimulation and then stimulating the cells with different matter.

20. A method according to any of claims 17 to 19 which includes the step of multiplying selected cells on the carrier in order to increase their number.

21. A method according to claim 17 which includes the steps of expelling selected cells from carrier apertures and subsequently multiplying them in order to increase their number.

22. A method according to claim 17 which further includes the step of killing at least one cell which is not among the selected cells while the cell is in situ, namely in an aperture of the carrier.

23. A method according to claim 22 which further includes the step of multiplying the live cells on the carrier in situ.

24. A method according to claim 23 which further includes the step of observing the multiplication process of at least one cell which multiplies in situ.

25. A method according to any of claims 17 to 24, wherein the precise location of each aperture is identifiable by its position with respect to coordinates on the x and y axes of said planar carrier.

26. A method according to any of claims 17 to 25, wherein said attracting and/or expelling step is effected by electromagnetic means.

27. A method according to any of claims 17 to 25, wherein said attracting and/or expelling step is effected by means for producing a pressure difference across at least a selected portion of said carrier.

28. A method according to any of claims 17 to 25, wherein the adherence of cells in said apertures is enhanced by means adapted for this purpose.

#### Patentansprüche

1. Vorrichtung zum Auslesen bestimmter biologischer Zellen von anderen Zellen und zum Beobachten zumindest einer bestimmten Eigenschaft der ausgelesenen Zellen, wobei die Vorrichtung umfaßt:

Einen im wesentlichen ebenen Träger (1) vorgegebener Dicke mit oberen und unteren Oberflächen und mit einer geordneten Anordnung von sich dadurch erstreckenden Öffnungen (2), wobei die Öffnungen eine vorbestimmte Konfiguration mit vorbestimmten Abmessungen an den oberen und unteren Oberflächen aufweisen, die als Ober- bzw. Bodenabmessungen bezeichnet werden, wodurch, wenn biologische Zellen auf die obere Oberfläche aufgebracht werden, nur ausgewählte Zellen vorgewählter Abmessungen in den Öffnungen im wesentlichen zurückgehalten werden

mit im wesentlichen einer Zelle pro Öffnung, dadurch gekennzeichnet, daß die Oberabmessung jeder Öffnung größer ist als ihre kleinste innere Querschnittsabmessung und die Dicke des Trägers und die Oberabmessungen jeder Öffnung von der Größenordnung des Durchmesser der gewählten Zellen sind.

2. Vorrichtung nach Anspruch 1, dadurch gekennzeichnet, daß Ober- und Bodenabmessungen jeder Öffnung im Bereich von Mikrometern liegen.

3. Vorrichtung nach Anspruch 1, dadurch gekennzeichnet, daß die Öffnungen (2) so bemessen sind, daß sie Lymphozyten zurückhalten, eine pro Öffnung.

4. Vorrichtung nach einem oder mehreren der Ansprüche 1 bis 3, dadurch gekennzeichnet, daß die genaue Lage jeder Öffnung bestimmbar ist durch ihre Position mit Bezug auf Koordinaten von X- und Y-Achsen des ebenen Trägers.

5. Vorrichtung nach einem oder mehreren der vorhergehenden Ansprüche, dadurch gekennzeichnet, daß weiterhin erste Gerüstmittel (10, 40) vorgesehen sind, um den Träger an einer bestimmten Stelle darauf zu stützen, wodurch jede Öffnung des Trägers an einer bekannten Stelle angeordnet ist, die als eine Adresse mit Bezug auf die Gerüstmittel definiert werden kann, Instrumente (Fig. 4, 5, 6b) um zumindest eine Zelleigenschaft zu beobachten und/oder zu messen und Steuermittel (94), um die Relativbewegung und die Arbeit der Instrumente mit Bezug auf den Träger zu steuern und dadurch die Beobachtung und/oder Messung zumindest einer Zelleigenschaft einer Zelle in einer beliebigen der Öffnungen, ausgehend von ihrer Adresse, zu ermöglichen.

6. Vorrichtung nach Anspruch 5, dadurch gekennzeichnet, daß die Instrumente optische Untersuchungsmittel (86, 87) umfassen, um die optischen Eigenschaften einer beliebigen der Zellen zu bestimmen.

7. Vorrichtung nach Anspruch 5, dadurch gekennzeichnet, daß die ersten Gerüstmittel (10) Einrichtungen aufweisen, um eine Vielzahl von voneinander eintfernt angeordneten Trägern zu stützen, wobei jeder Träger in seinen Öffnungen Zellen aufweist und zweite Gerüstmittel (11), die selektiv in Bezug auf die ersten Gerüstmittel anordbar sind, um die Zellen auf jedem der voneinander eintfernt angeordneten Träger gleichzeitig durch eine vorgewählte Materie stimulieren zu können, wobei die Steuermittel (94) dazu angepaßt sind, eine Relativbewegung der Instrumente zu steuern mit Bezug auf einen beliebigen der Träger, und dadurch die Beobachtung und/oder Messung zumindest einer Zelleigenschaft einer Zelle in irgendeiner speziellen der Öffnungen zur ermöglichen, ausgehend von ihrer Adresse.

8. Vorrichtung nach Anspruch 7, dadurch gekennzeichnet, daß die ersten und zweiten Gerüstmittel mit Bezug aufeinander angeordnet werden können, wodurch die Zellen angeregt werden können, indem sie durch entweder das

Ober- oder das Unterende der Öffnungen befeuchtet werden.

9. Vorrichtung nach Anspruch 7, dadurch gekennzeichnet, daß die zweiten Gerüstmittel Einrichtungen aufweisen, um verschiedene Anregungsmittel darin aufzuweisen, wodurch Zellen in zumindest einigen der Öffnungen von im Abstand voneinander angeordneten Trägern gleichzeitig angeregt werden können durch die verschiedenen Anregungsmittel.

10. Vorrichtung nach einem oder mehreren der Ansprüche 1 bis 6, gekennzeichnet durch Einrichtungen, die eine Kraft aufbringen können, um beliebige der Zellen an die Öffnungen anzuziehen oder von diesen abzustoßen.

11. Vorrichtung nach Anspruch 10, dadurch gekennzeichnet, daß diese kraftaufbringenden Mittel Vorrichtungen umfassen, welche in einem vorgegebenen Muster, bezogen auf die Öffnungen, angeordnet sind, um eine oder mehrere Zellen von den Öffnungen abzustoßen oder zu diesen anzuziehen durch elektromagnetische Mittel (101).

12. Vorrichtung nach Anspruch 10, dadurch gekennzeichnet, daß diese Kraftmittel Vorrichtungen aufweisen (Fig. 11), um einen Druckunterschied aufzubauen über zumindest einem bestimmten Abschnitt des oder der Träger.

13. Vorrichtung nach Anspruch 10, dadurch gekennzeichnet, daß die Kraftmittel Vorrichtungen umfassen (115, 116, 117), um das Anhaften der Zellen in den Öffnungen zu verbessern.

14. Vorrichtung nach einem oder mehreren der Ansprüche 10 bis 13, dadurch gekennzeichnet, daß die ersten Gerüstmittel (10) Einrichtungen aufweisen, um eine Vielzahl von im Abstand zueinander angeordneten Trägern zu stützen, wobei jeder Träger Zellen in seinen Öffnungen aufweist, und zweite Gerüstmittel (11), die selektiv, bezogen auf die ersten Gerüstmittel, angeordnet, werden können, um eine gleichzeitige Anregung der Zellen auf jedem der im Abstand voneinander angeordneten Träger durch eine vorgewählte Materie zu ermöglichen, mit Steuermitteln (94), die angepaßt sind, um eine Relativbewegung der Instrumente mit Bezug auf einen beliebigen der Träger zu steuern und dadurch die Beobachtung und/oder Messung zumindest einer Zelleigenschaft einer Zelle in irgendeiner bestimmten der Öffnungen, aufgrund ihrer Adresse, zu ermöglichen.

15. Vorrichtung nach Anspruch 14, dadurch gekennzeichnet, daß die ersten und zweiten Gerüstmittel mit Bezug zueinander angeordnet werden können, wodurch die Zellen angeregt werden können, indem sie entweder durch das Bodenende oder das obere Ende der Öffnungen befeuchtet werden.

16. Vorrichtung nach Anspruch 14, dadurch gekennzeichnet, daß die zweiten Gerüstmittel Einrichtungen aufweisen, um darin verschiedene Anregungsmittel zu enthalten, wodurch Zellen in zumindest einigen der Öffnungen der im Abstand voneinander angeordneten Träger gleichzeitig durch die verschiedenen Anregungs-

mittel angeregt werden können.

17. Verfahren zur Auslese besonderer biologischer Zellen von anderen Zellen, um die Beobachtung von zumindest einer ausgewählten Eigenschaft der ausgewählten biologischen Zellen zu vereinfachen, wobei diese Methode umfaßt, im wesentlichen mit den Zellen, einschließlich der ausgewählten interessanten Zellen, die obere Oberfläche zu bedecken, eines im wesentlichen ebenen Trägers von einer vorgewählten Dicke, und der obere und untere Oberflächen aufweist und eine geordnete Anordnung von Öffnungen dadurch aufweist, wobei diese Öffnungen eine vorgewählte Konfiguration mit vorgewählten Abmessungen an den oberen und unteren Oberflächen aufweisen und wobei die Methode einen Schritt beinhaltet, die obere Oberfläche des Trägers zu waschen, um Zellen zu entfernen, die nicht von den Öffnungen gehalten werden, wodurch lediglich ausgewählte Zellen von vorgewählten Abmessungen im wesentlichen in den Öffnungen zurückgehalten werden mit im wesentlichen einer Zelle pro Öffnung, dadurch gekennzeichnet, daß die obere Abmessung jeder Öffnung größer als ihre kleinste innere Querschnittsabmessung und sowohl die Dicke des Trägers als auch die oberen Abmessungen jeder Öffnung in der Größenordnung der Durchmesser der ausgewählten Zellen geschaffen wird und daß der Schritt, eine beliebige Zelle zu der Öffnung anzuziehen, in welcher sie gehalten werden soll oder bei dem die Zelle von der Öffnung, in der sie gehalten wird, abgestoßen wird, eine Funktion einer bekannten Zelleigenschaft ist.

18. Verfahren nach Anspruch 17, dadurch gekennzeichnet, daß es weiterhin einen Schritt aufweist, die Zellen in den Trägeröffnungen nach einer vorherigen Anregung so zu behandeln, daß sie im wesentlichen in ihren ursprünglichen Zustand zurückversetzt werden.

19. Verfahren nach Anspruch 18, dadurch gekennzeichnet, daß es weiterhin die Schritte aufweist, die Zellen in den Trägeröffnungen zu neutralisieren nach einer vorhergehenden Anregung und sie dann mit einer anderen Materie wieder anzuregen.

20. Verfahren nach einem oder mehreren der Ansprüche 17 bis 19, gekennzeichnet durch einen Schritt, ausgewählte Zellen auf dem Träger zu vervielfältigen, um ihre Anzahl zu erhöhen.

21. Verfahren nach Anspruch 17, gekennzeichnet durch die Schritte, ausgewählte Zellen von den Trägeröffnungen abzustoßen und sie anschließend zu vervielfältigen, um ihre Anzahl zu erhöhen.

22. Verfahren nach Anspruch 17, gekennzeichnet, durch ferner den Schritt, zumindest eine Zelle zu töten, welche nicht unter die ausgewählten Zellen fällt, während die Zelle an Ort und Stelle befindlich ist, nämlich in einer Öffnung des Trägers.

23. Verfahren nach Anspruch 22, gekennzeichnet durch ferner einen Schritt, die lebenden Zel-

len an Ort und Stelle auf dem Träger zu vervielfältigen.

24. Verfahren nach Anspruch 23, dadurch gekennzeichnet, daß es ferner einen Schritt aufweist, den Vervielfältigungsprozeß von zumindest einer Zelle zu beobachten, welche sich an Ort und Stelle vervielfältigt.

25. Verfahren nach einem oder mehreren der Ansprüche 17 bis 24, dadurch gekennzeichnet, daß die genaue Anordnung jeder Öffnung identifizierbar ist durch ihre Lage in Bezug auf Koordinaten von X- und Y-Achsen des ebenen Trägers.

26. Verfahren nach einem oder mehreren der Ansprüche 17 bis 25, dadurch gekennzeichnet, daß der anziehende oder abstoßende Schritt durch elektromagnetische Mittel erreicht wird.

27. Verfahren nach einem oder mehreren der Ansprüche 17 bis 25, dadurch gekennzeichnet, daß der anziehende oder abstoßende Schritt durch Mittel bewirkt wird, welche eine Druckdifferenz über zumindest einen ausgewählten Abschnitt des Trägers erzeugen.

28. Verfahren nach einem oder mehreren der Ansprüche 17 bis 25, dadurch gekennzeichnet, daß die Haftung der Zellen in den Öffnungen verbessert wird durch zweckdienliche Mittel.

#### Revendications

1. Appareil pour sélectionner des cellules biologiques particulières parmi d'autres cellules et pour observer au moins une propriété choisie des cellules biologiques sélectionnées, ledit appareil comprenant un support (1), sensiblement plan, d'une épaisseur présélectionnée, et définissant des surfaces supérieure et inférieure, et comprenant un réseau ordonné d'ouvertures (2) qui le traversent, lesdites ouvertures présentant une configuration présélectionnée avec des dimensions présélectionnées au niveau des surfaces de sommet et de fond, pouvant être définies respectivement comme dimensions de sommet et de fond, d'où il résulte que, lorsque les cellules biologiques sont disposées sur ladite surface de sommet, seules des cellules sélectionnées de dimensions présélectionnées sont maintenues sensiblement dans lesdites ouvertures à raison de pratiquement une cellule par ouverture, caractérisé par le fait que la dimension de sommet de chaque ouverture est supérieure à sa plus petite dimension interne en coupe transversale, et à la fois l'épaisseur dudit support et les dimensions de sommet de chaque ouverture sont de l'ordre des dimètres des cellules sélectionnées.

2. Appareil selon la revendication 1, caractérisé en ce que les dimensions de sommet et de fond de chaque ouverture sont de l'ordre de micromètres.

3. Appareil selon la revendication 1, caractérisé en ce que les ouvertures sont dimensionnées pour maintenir des lymphocytes, à raison d'un par ouverture.

4. Appareil selon l'une des revendications 1 à 3, caractérisé en ce que l'emplacement précis de

chaque ouverture est identifiable par sa position par rapport aux coordonnées sur les axes des x et des y dudit support plan.

5. Appareil selon l'une des revendications précédentes, caractérisé en ce qu'il comporte en outre des premiers moyens porteurs (10; 40) pour supporter ledit support à un emplacement défini sur ceux-ci, d'où il résulte que chaque ouverture dudit support est située à un emplacement connu, pouvant être défini comme une adresse, par rapport auxdits moyens porteurs, des moyens d'instrumentation (figures 4, 5, 6B) pour observer et/ou mesurer au moins une propriété cellulaire, et des moyens de contrôle (94) pour contrôler le mouvement relatif et le fonctionnement desdits moyens d'instrumentation par rapport audit support, et permettant ainsi d'effectuer l'observation et/ou la mesure d'au moins une propriété cellulaire d'une cellule dans n'importe quelle ouverture particulière parmi lesdites ouvertures, sur la base de son adresse.

6. Appareil selon la revendication 5, caractérisé en ce que lesdits moyens d'instrumentation comprennent des moyens de balayage optique (86, 87) pour déterminer des propriétés optiques de n'importe laquelle parmi lesdites cellules.

7. Appareil selon la revendication 5, caractérisé en ce que lesdits premiers moyens porteurs (10) comprennent des moyens pour supporter une pluralité de supports espacés les uns des autres, chaque support présentant des cellules dans ses ouvertures, et des seconds moyens porteurs (11) que l'on peut positionner de façon sélective par rapport auxdits premiers moyens porteurs, pour permettre aux cellules présentes sur chacun desdits supports espacés les uns des autres d'être stimulées de façon simultanée par une matière présélectionnée, lesdits moyens de contrôle (94) étant capables de diriger le mouvement relatif desdits moyens d'instrumentation par rapport à l'un quelconque parmi lesdits supports, et permettant ainsi d'effectuer l'observation et/ou la mesure d'au moins une propriété cellulaire d'une cellule dans n'importe quelle ouverture particulière parmi lesdites ouvertures, sur la base de son adresse.

8. Appareil selon la revendication 7, caractérisé en ce que lesdits premiers et seconds moyens porteurs sont aptes à être positionnés les uns par rapport aux autres d'où il résulte que lesdites cellules sont stimulables en étant humectées par, ou bien l'extrémité de sommet, ou bien l'extrémité de fond, desdites ouvertures.

9. Appareil selon la revendication 7, caractérisé en ce que lesdits seconds moyens porteurs comprennent des moyens pour contenir différentes matières stimulantes à l'intérieur de ceux-ci, d'où il résulte que des cellules dans au moins quelques-unes des ouvertures desdites supports espacés les uns des autres peuvent être stimulées de façon simultanée par lesdites différentes matières stimulantes.

10. Appareil selon l'une des revendications 1 à 6, caractérisé en ce qu'il comprend également des moyens produisant une force pour attirer ou



expulser n'importe laquelle parmi lesdites cellules vers les ou à partir des ouvertures.

11. Appareil selon la revendication 10, caractérisé en ce que lesdits moyens produisant une force comprennent des moyens disposés selon un motif prédéterminé par rapport auxdites ouvertures pour attirer ou expulser une ou plusieurs desdites cellules vers les ou à partir des ouvertures par des moyens électromagnétiques (101).

12. Appareil selon la revendication 10, caractérisé en ce que lesdits moyens produisant une force comprennent des moyens (figure 11) pour produire une différence de pression à travers au moins une partie sélectionnée dudit (ou desdits) support(s).

13. Appareil selon la revendication 10, caractérisé en ce que lesdits moyens produisant une force comprennent des moyens (115, 116, 117) pour augmenter l'adhésion des cellules dans lesdites ouvertures.

14. Appareil selon l'une des revendications 10 à 13, caractérisé en ce que lesdits premiers moyens porteurs (10) comprennent des moyens pour supporter une pluralité de supports espacés les uns des autres, chaque support présentant des cellules dans ses ouvertures, et des seconds moyens porteurs (11) que l'on peut positionner de façon sélective par rapport auxdits premiers moyens porteurs, pour permettre aux cellules présentes sur chacun desdits supports espacés les uns des autres d'être stimulée de façon simultanée par une matière présélectionnée, lesdits moyens de contrôle (94) étant adaptés pour diriger le mouvement relatif desdits moyens d'instrumentation par rapport à n'importe lequel parmi lesdits supports, et permettant ainsi d'effectuer l'observation et/ou la mesure d'au moins une propriété cellulaire d'une cellule dans n'importe quelle ouverture particulière parmi lesdites ouvertures, sur la base son adresse.

15. Appareil selon la revendication 14, caractérisé en ce que lesdits premiers et seconds moyens porteurs sont aptes à être positionnés les uns par rapport aux autres, d'où il résulte que lesdites cellules sont stimulables en étant humectées par, ou bien l'extrémité de sommet ou bien l'extrémité de fond, desdites ouvertures.

16. Appareil selon la revendication 14, caractérisé en ce que lesdits seconds moyens porteurs comprennent des moyens pour contenir différentes matières simultanées à l'intérieur de ceux-ci, d'où résulte que des cellules présentes dans au moins quelques-unes des ouvertures desdits supports espacés les uns des autres, pouvant être stimulées de façon simultanée par lesdites différentes matières stimulantes.

17. Procédé pour sélectionner des cellules biologiques particulières parmi d'autres cellules pour faciliter l'observation d'au moins une propriété choisie des cellules biologiques sélectionnées, ledit procédé consistant à couvrir pratiquement, avec les cellules, y compris les cellules intéressantes sélectionnées, la surface supérieure d'un support sensiblement plan, d'une

épaisseur présélectionnée, et définissant des surfaces supérieure et inférieure, et comprenant un réseau ordonné d'ouvertures qui le traversent, lesdites ouvertures présentant une configuration présélectionnée avec des dimensions présélectionnées au niveau des surfaces de sommet et de fond, et ledit procédé comprenant l'étape consistant à laver ladite surface supérieure dudit support pour retirer les cellules non supportées dans lesdites ouvertures, d'où il résulte que seules des cellules sélectionnées de dimensions présélectionnées sont maintenues sensiblement dans lesdites ouvertures à sont maintenues sensiblement dans lesdites ouvertures à raison de pratiquement une cellule par ouverture, caractérisé par le fait que l'on prévoit la dimension de sommet de chaque ouverture supérieure à sa plus petite dimension interne en coupe transversale, et à la fois l'épaisseur dudit support et les dimensions de sommet de chaque ouverture, de l'ordre des diamètres des cellules sélectionnées, et l'étape consistant à attirer toute cellule vers l'ouverture dans laquelle elle doit être supportée, ou à expulser toute cellule de l'ouverture dans laquelle elle est supportée, en fonction d'une propriété cellulaire connue.

18. Procédé selon la revendication 17, caractérisé en ce qu'il comprend en outre l'étape consistant à traiter les cellules dans les ouvertures du support après une stimulation préalable pour les faire retourner sensiblement à leur état précédent.

19. Procédé selon la revendication 18, caractérisé en ce qu'il comprend en outre les étapes consistant à neutraliser les cellules dans les ouvertures du support après une stimulation préalable et, ensuite, à stimuler les cellules avec une matière différente.

20. Procédé selon l'une des revendications 17 à 19, caractérisé en ce qu'il comprend l'étape consistant à faire se multiplier des cellules sélectionnées sur le support de façon à augmenter leur nombre.

21. Procédé selon la revendication 17, caractérisé en ce qu'il comprend les étapes consistant à expulser les cellules sélectionnées des ouvertures du support et, ensuite, à les faire se multiplier de façon à augmenter leur nombre.

22. Procédé selon la revendication 17, caractérisé en ce qu'il comprend en outre l'étape consistant à tuer au moins une cellule qui n'est pas parmi les cellules sélectionnées alors que la cellule se trouve in situ, à savoir dans une ouverture de support.

23. Procédé selon la revendication 22, caractérisé en ce qu'il comprend en outre l'étape consistant à faire se multiplier les cellules vivantes sur le support in situ.

24. Procédé selon la revendication 23, caractérisé en ce qu'il comprend en outre l'étape consistant à observer le processus de multiplication d'au moins une cellule que se multiplie in situ.

25. Procédé selon l'une des revendications 17 à 24, caractérisé en ce que l'emplacement précis de chaque ouverture est identifiable par sa posi-

33

**0 094 193**

34

tion par rapport aux coordonnées sur les axes des x et des y dudit support plan.

26. Procédé selon l'une des revendications 17 à 25, caractérisé en ce que ladite étape d'attraction et/ou d'expulsion est effectuée par des moyens électromagnétiques.

27. Procédé selon l'une des revendications 17 à 25, caractérisé en ce que ladite étape d'attraction

et/ou d'expulsion est effectuée par des moyens pour produire une différence de pression à travers au moins une partie choisie dudit support.

28. Procédé selon l'une des revendications 17 à 25, caractérisé en ce que l'adhésion des cellules dans lesdites ouvertures est augmentée par des moyens adaptés à ce but.

5

10

15

20

25

30

35

40

45

50

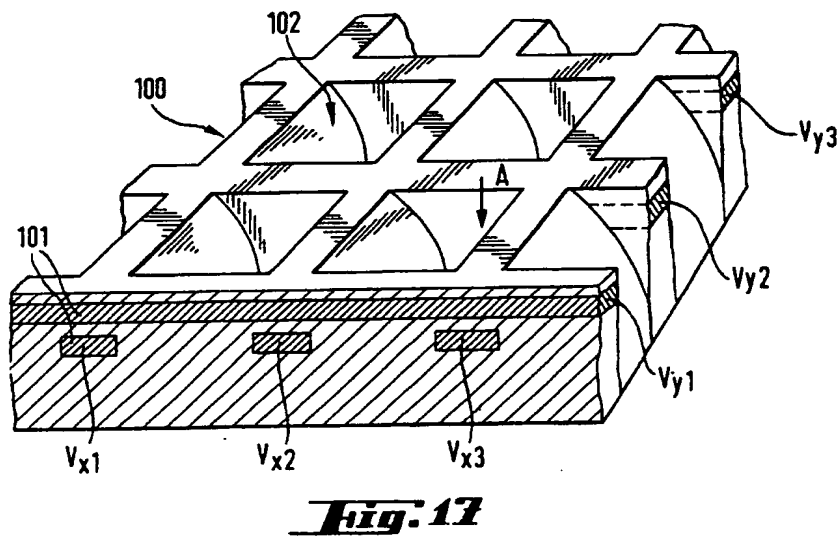
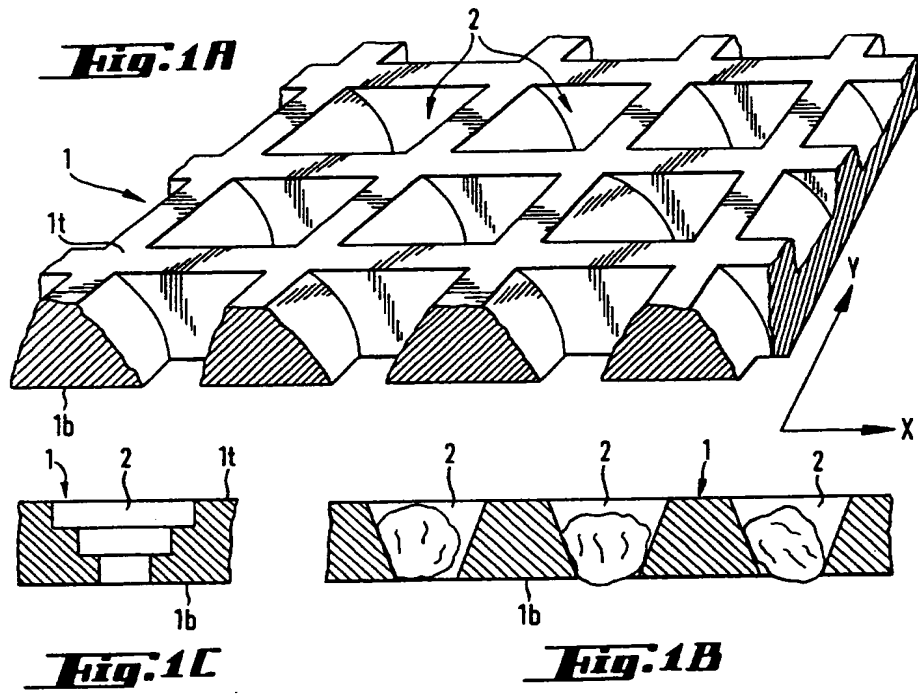
55

60

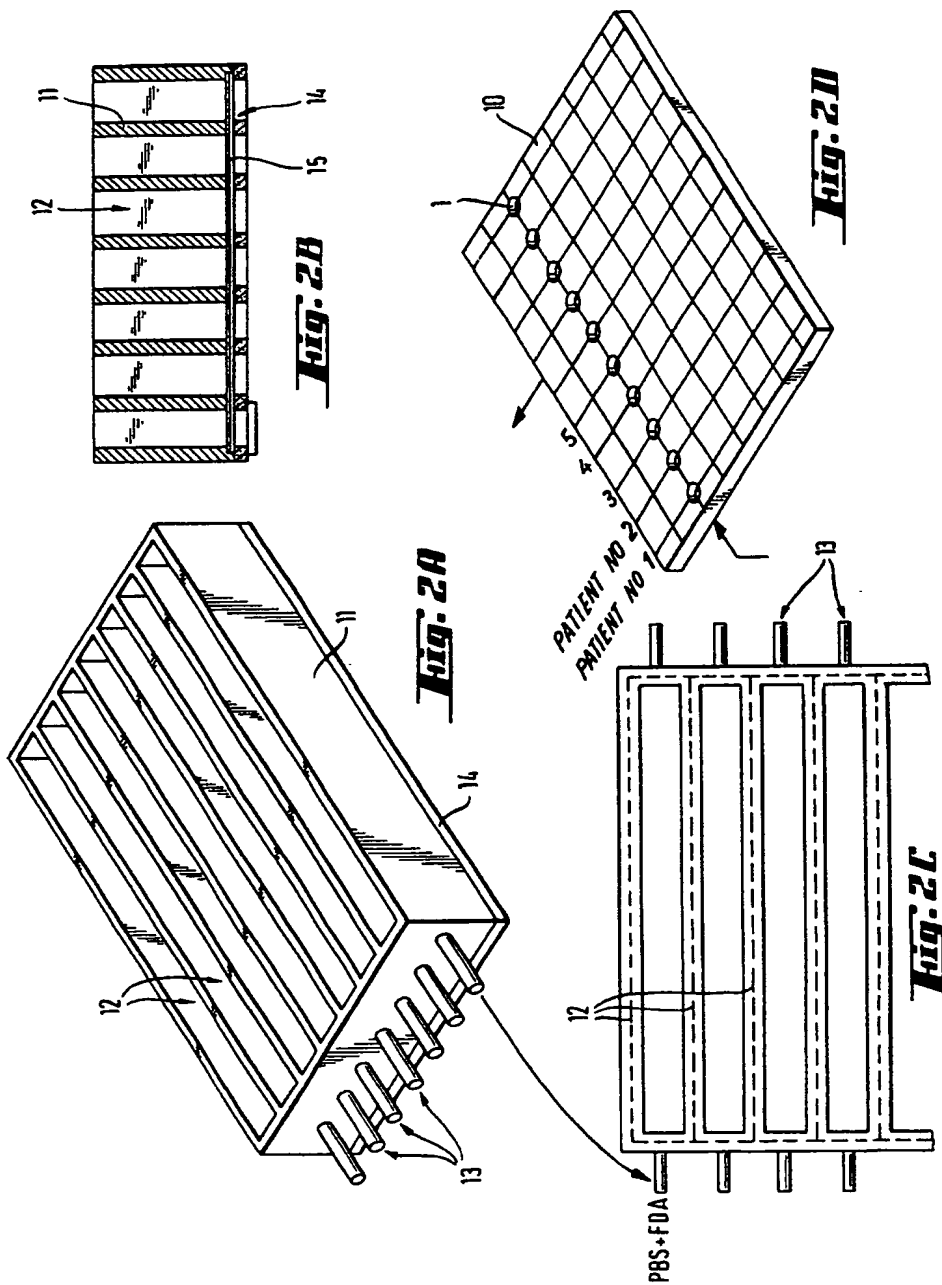
65

18

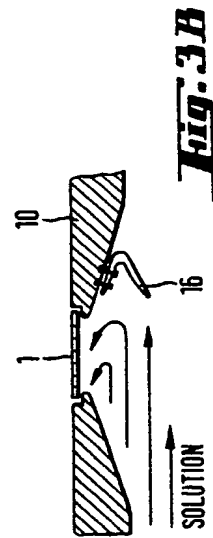
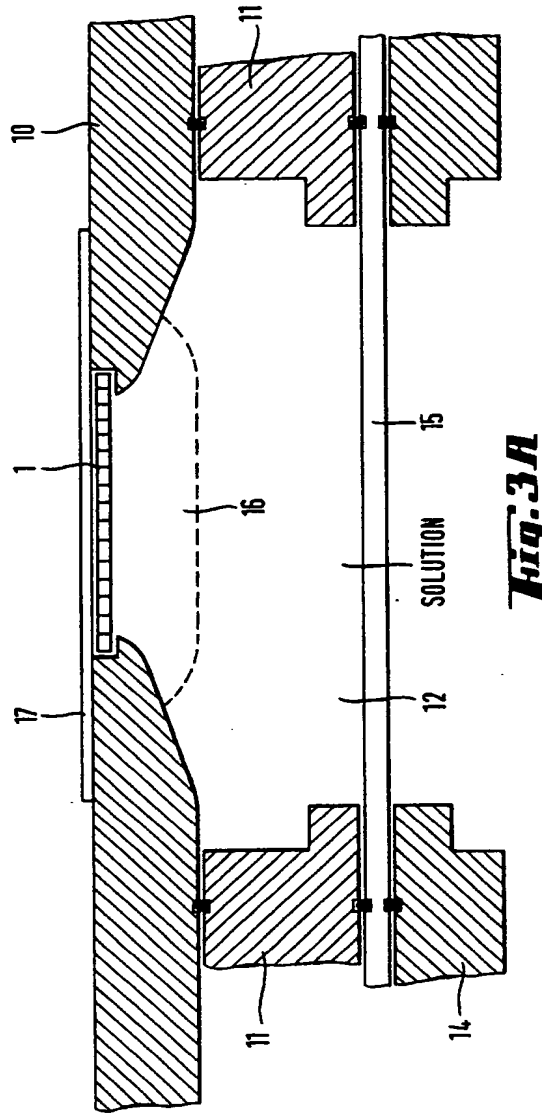
0 094 193



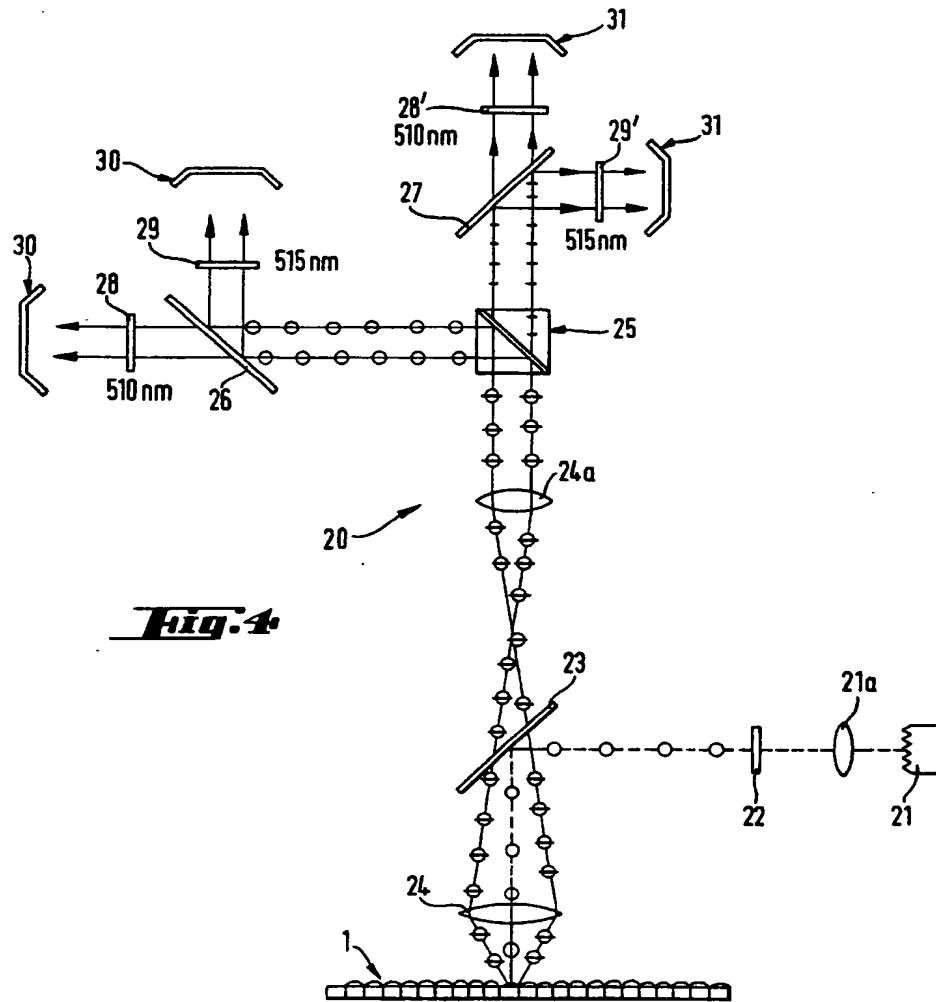
0 094 193



0 094 193

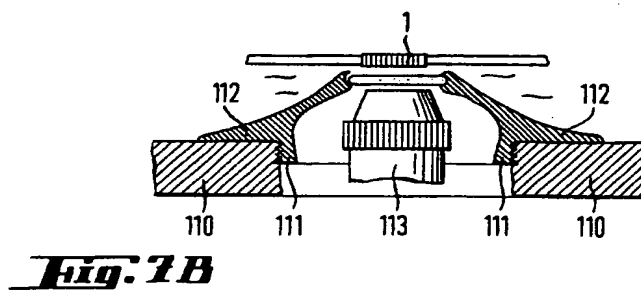
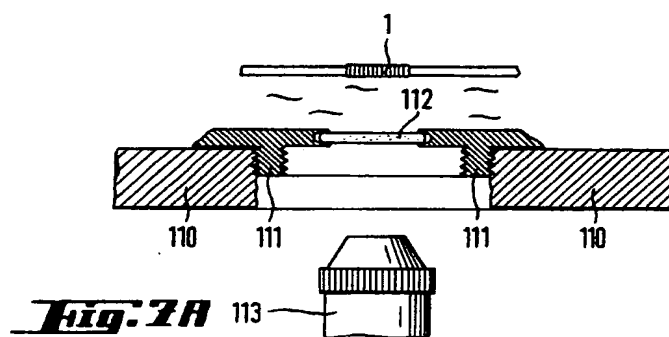
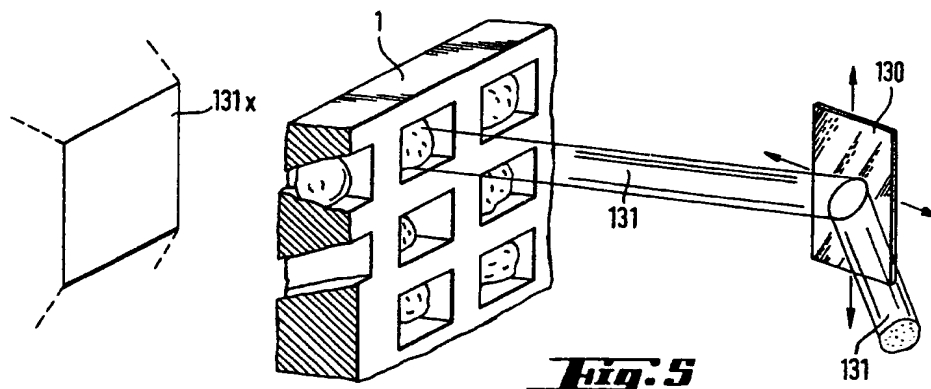


0 094 193

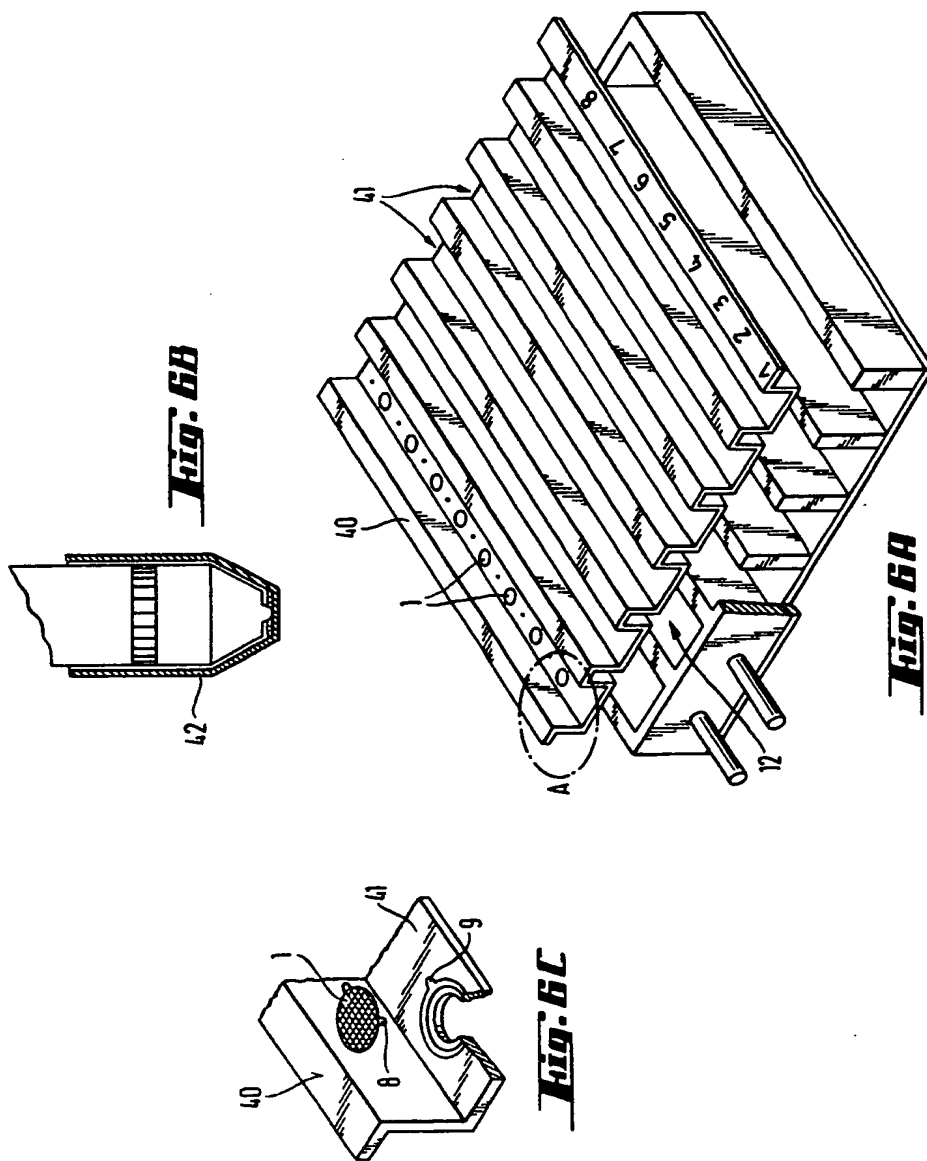


**Fig. 4**

0 094 193

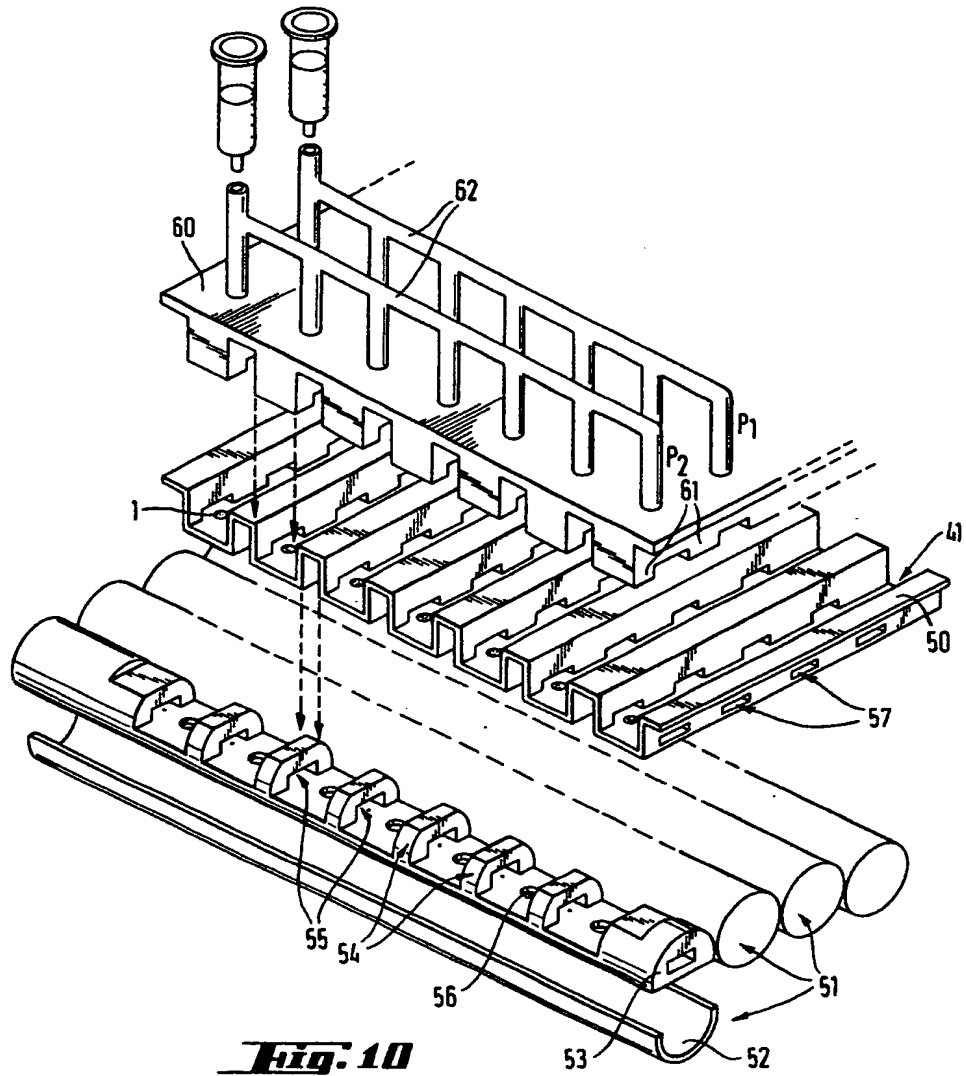


0 094 193



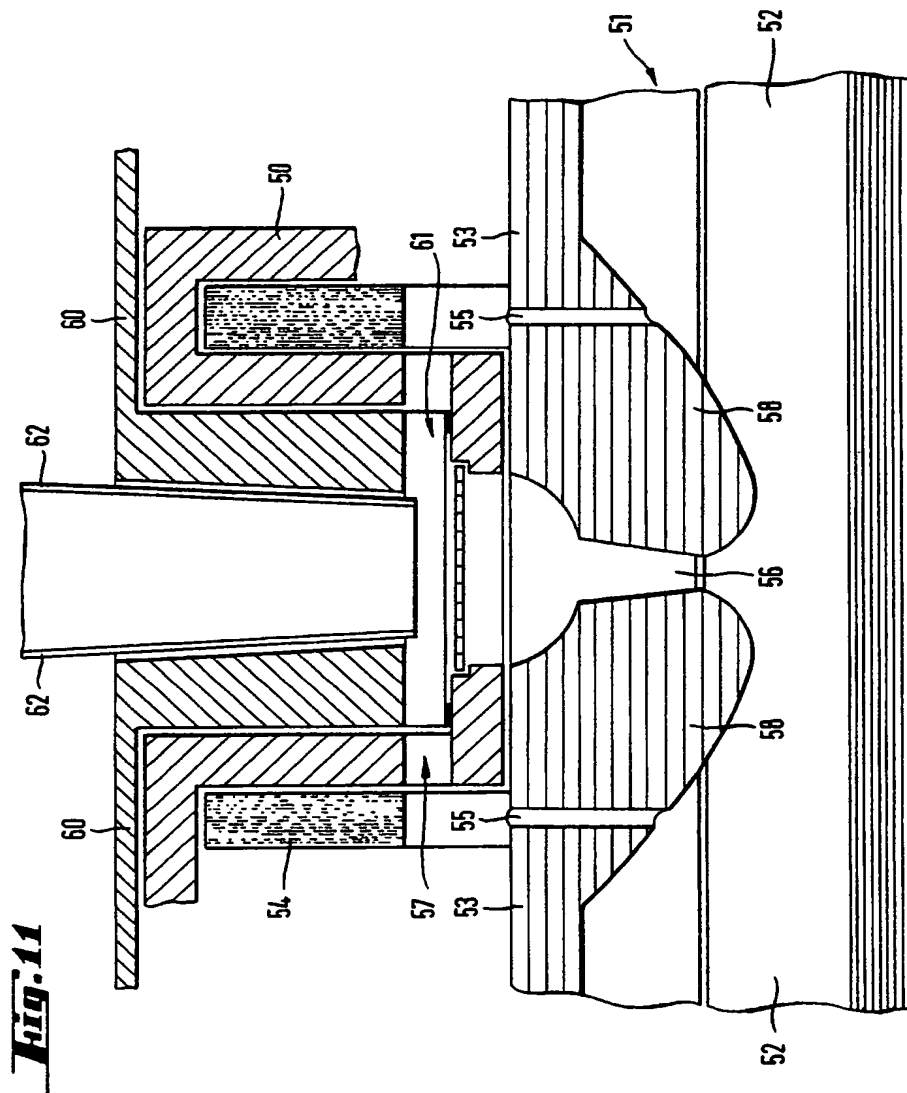


0 094 193

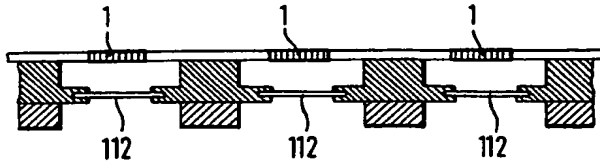


**Fig. 10**

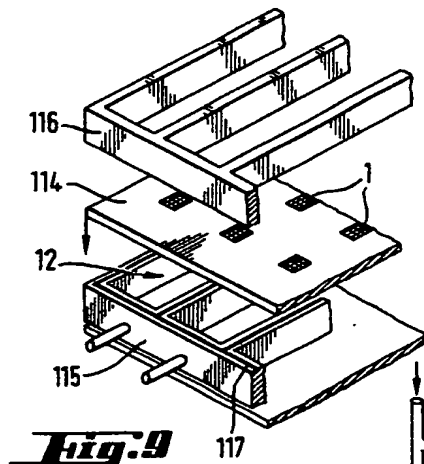
0 094 193



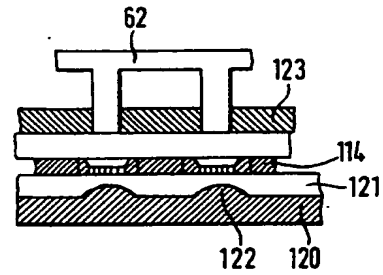
0 094 193



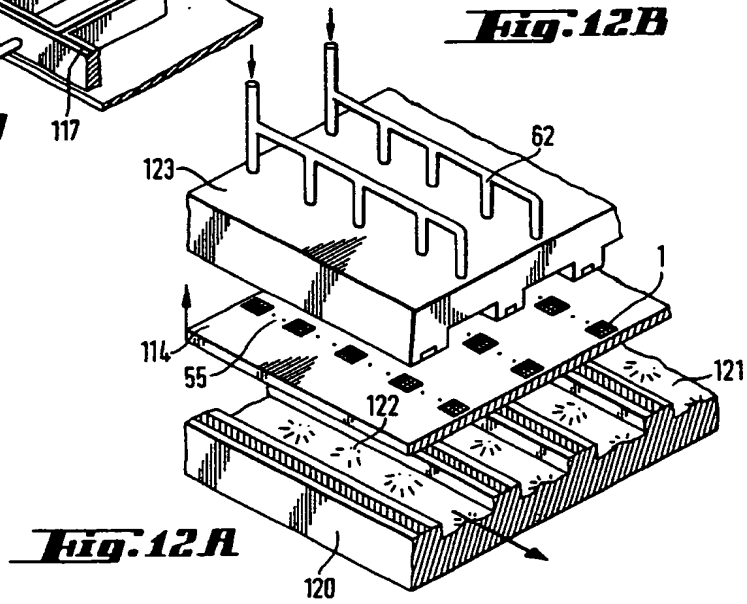
**Fig. 8**



**Fig. 9**

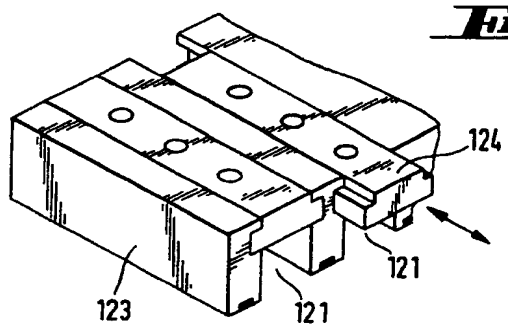


**Fig. 12B**

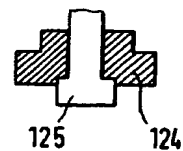


**Fig. 12A**

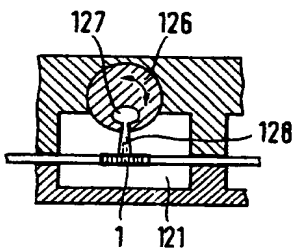
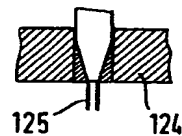
0 094 193



**Fig. 13 B**

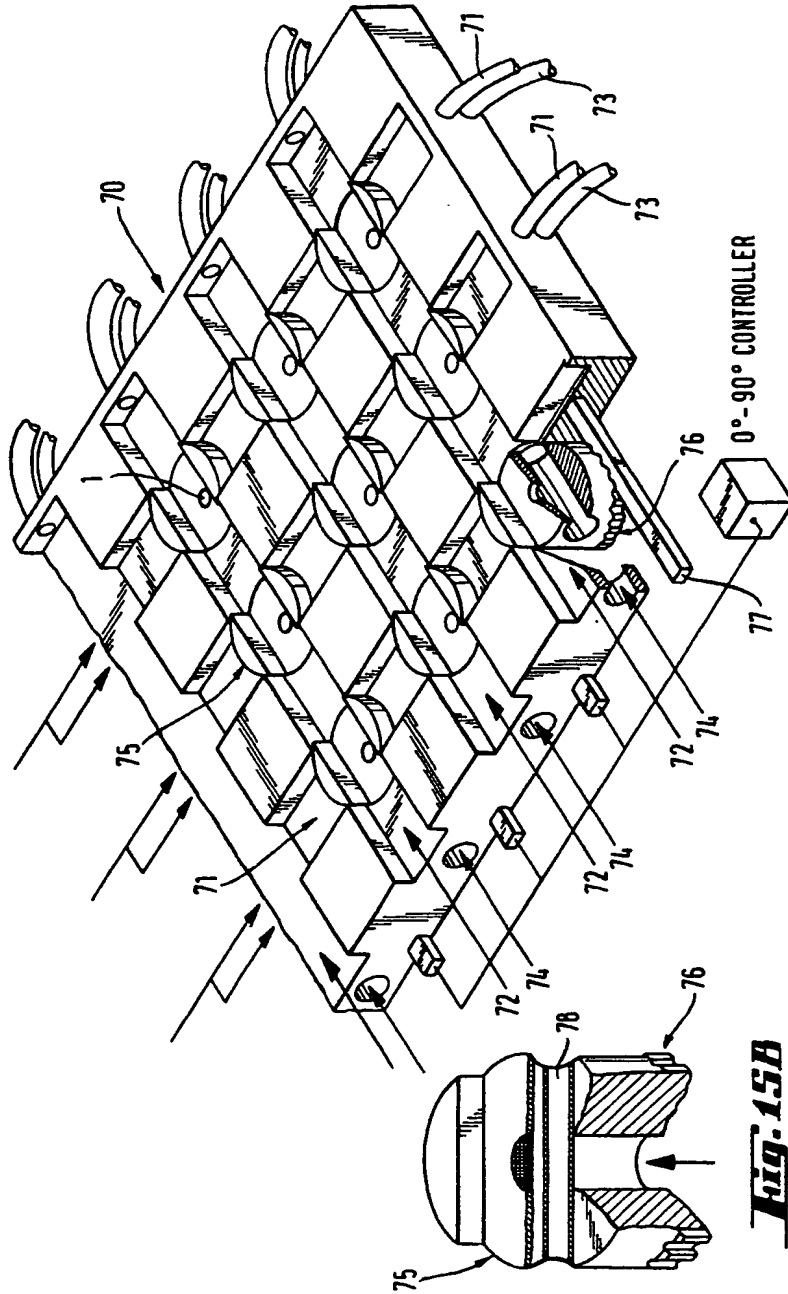


**Fig. 13 C**



**Fig. 14**

0 094 193



**Fig. 15A**

**Fig. 15B**

0 094 193

